

# Millennium Controller MC Series Installation and Operation Manual

For Kernel 0.96

00-02-0478  
Revised 02-07  
Section 50



Please read the following information before installing. A visual inspection of this product for damage during shipping is recommended before mounting. It is your responsibility to have a qualified person install this unit and make sure it conforms to NEC and local codes.

## GENERAL INFORMATION

# WARNING

BEFORE BEGINNING INSTALLATION OF THIS MURPHY PRODUCT

- ✓ Disconnect all electrical power to the machine.
- ✓ Make sure the machine cannot operate during installation.
- ✓ Follow all safety warnings of the machine manufacturer.
- ✓ Read and follow all installation instructions.



Approved  
Class I, Div. 2  
Groups C & D



## Description

MC Series Millennium Controller is a PC-based monitoring, control and data acquisition system. Designed with engine-driven compressors in mind, the MC Series is suitable for a wide range of industrial applications. As the heart of the control package, the MC series continuously monitors inputs and set points for correct operation. When an out-of-limit event occurs, the controller provides an alphanumeric readout of critical machinery data or shutdown fault information.

In addition to the shutdown and control functions, the MC series controller provides both local and remote communications of vital equipment and operating data. This advanced system offers multiple options for remote communications. A serial link is provided for Programmable Logic Controllers, PC's and SCADA systems. Radio and satellite communications are accommodated through the MODBUS RTU protocol. Operations analysis and maintenance is facilitated by the operation hours and data trending system. The shutdown snapshot feature gives operators a complete picture of system conditions at shutdown.

## Basic Components

### Controller Display PC Modules (head)

**MCH-L-M:** 586 compatible processor, 100 MHz; 8 MB RAM, LCD Display.

**MCH-V-M:** 586 compatible processor, 100 MHz; 8 MB RAM; VFD Display.

### Power Supply

**MCPS-NA:** no analog outputs.

**MCPS-A1:** one analog output.

**MCPS-A2:** two analog outputs.

## Optional I/O Expansion Modules

### C267 Module *UL/cUL Listed, Class I, Div. 2 Groups C & D*

The C267 adds standard I/O capability to the Murphy Millennium Controllers via MODBUS RTU communication. The C267 includes 8 digital inputs, 7 analog inputs, power supply monitor, 8 discrete outputs and 1 frequency input for speed sensing.

### C277 Module *UL/cUL Listed, Class I, Div. 2 Groups C & D*

The C277 adds temperature sensing capabilities to the Murphy Millennium Controllers through MODBUS RTU communications via an RS485 port. The C277 can read up to 18 ungrounded thermocouples or mA sources from pressure transmitters and other transmitters.

### C287 Module *UL/cUL Listed, Class I, Div. 2 Groups C & D*

The C287 adds precision analog inputs and additional analog outputs to the Murphy Millennium Controllers via Modbus RTU communications. The C287 includes four 15-bit analog inputs, four 16-bit analog outputs (all 4-20mA).

## Optional Hold Up Capacitor Package

### MCCP Model

The MCCP module is an optional Hold Up Capacitor Package that allows the MC Series Millennium Controller to work flawlessly with 12 VDC cranking battery systems.

## MC Series General Specifications

**NOTE:** The system is intended for mounting in a weatherproof enclosure.

**Power Input:** 10-32 VDC, 26 watts maximum.

**Operating Temp.:** -40 to 85°C (-40 to 185°F)

Base Unit w/VFD Display: -40 to 85°C (-40 to 185°F).

Base Unit w/LCD Display: -20 to 70°C (-4 to 158°F).

**Programming:** PC-based Ladder Logic.

## Specifications continued

### Display Module Specifications

#### MCH-L-M Controller Display Module:

- 586 compatible microprocessor, includes 8 MB of RAM.
- 4-lines with 20 characters each, liquid crystal display.
- 16-key user interface: set point entry, alarm acknowledgement, start, stop, reset, etc.
- 4 RS485 serial ports: power supply, serial I/O, modbus slave, spare.
- 2 RS232 for ladder logic programming/monitoring or remote communications.
- 8 MB DISKONCHIP® for increased data storage capability.

#### MCH-V-M Controller Display Module:

- 586 compatible microprocessor and includes 8 MB of RAM.
- 4-lines with 20 characters, vacuum fluorescent display.
- 16-key user interface: set point entry, alarm acknowledgement, start, stop, reset etc.
- 4 RS-485 serial ports: power supply, serial I/O, modbus slave, spare.
- 2 RS-232 for ladder logic programming/monitoring or remote communications.
- 8 MB DISKONCHIP® for increased data storage capability.

### MCPS-A1; MCPS-A2 and MCPS-NA Power Supplies Specifications

- **16 Optically Isolated DC Digital Inputs** (NO or NC), sink or source, LED indicators, external power supply, or board supplied power, jumper selectable. Approved for use with general purpose passive mechanical switches in Division 2 hazardous areas.

- **Open Circuit** max. 32VDC, I short circuit max 9.2 mA.
- **Open Circuit** min. 10VDC, I short circuit min 2.5 mA.
- **Scan Time** 100 ms.
- **1 Magnetic Pickup Input/AC Run Signal:** 45 to 10kHz. 5 VAC rms min. 120 VAC rms max.
- **4 Solid State Relay Outputs:** External power must be supplied; 32 VDC max to 5.5 VDC min; I max 3A; short circuit and thermally protected; 100 ms scan time. Inductance 1 H max. @ 0.25 A, 5 mH max. @ 3A.
- **4 Mechanical Relay Outputs:** Form "C" contacts: Rating: 10 A 125 VAC, 6 A 250 VAC, 1/8 HP 125, 250 VAC, 5 A 30 VDC 100 ms scan time. Approved for Div. 2.
- **2 4-20mA Outputs:** 1-10 and/or 1-14 bit resolution (depending on model used) max. loop resistance  $RL = (Vps - 3.15) / 0.02 \Omega$ .
- **1 Digital Potentiometer Output:** 0-255 steps, 50K-Ohms, 27.5  $\mu$ W max., (other values of resistance available).
- **1 RS-485 Serial Port,** Modbus RTU Slave 38.4 Kbaud, half duplex.
- **MCPS-NA Power Supply:** No analog outputs
- **MCPS-A1 Power Supply:** One analog output (14 bit).
- **MCPS-A2 Power Supply:** Two analog outputs

### Expansion Modules Specifications C267 - 8 Digital Inputs - 7 Analog Inputs - 8 Digital outputs

**Input Voltage:** 9 to 28 VDC, 2.25 – 11 watts not including maximum 18 amps for outputs.

**Operating Temperature:** -22 to 158 °F (-30 to 70 °C).

**Storage Temperature:** -22 to 158 °F (-30 to 70 °C).

**Communications:** 1 – RS-485 9600-N-8-1 Communication port.

Connection is made via modular RJ45 Jack. There are two jacks for simple connection to other Comm Series Modules. The user can plug from the master controller into the C267. A second cable can then be run from the other jack to the next Comm Series Module. This can be repeated until the customers I/O resources are satisfied. The last module in the line must have a terminating resistor installed in the second jack (available from Murphy as part number 00005292).

**Digital Inputs:** 8 Optically isolated inputs (positive voltage or ground).

Approved for use with general purpose passive mechanical switches in Division 2 hazardous areas.

**Analog Inputs:** 7 - 8-bit. Each analog individually shunt selectable for 0-5 VDC, end of line 4-20 ma, or resistive sending unit.

**Frequency Input:** 1 - Optically isolated frequency input requiring 3 VAC rms up to 100 Hz and 2 VAC rms above 100 Hz. Used for speed reference. Range: 60 - 10,000 Hz.

**Outputs:** 8 - FET Outputs rated at 5A with a total current draw through the unit not to exceed 18A when both PWR2 pins are connected.

### C277 - 18 Analog Inputs

**Input Voltage:** 9 to 28 VDC, 0.6 watts.

**Operating Temperature:** -22 to 158 °F (-30 to 70 °C).

**Storage Temperature:** -22 to 158 °F (-30 to 70 °C).

**Communications:** 1 – RS-485 9600-N-8-1 Communication port.

Connection is made via modular RJ45 Jack. The C277 has two jacks to simplify connection to the Millennium controller. Typically, a connection is made in one jack and out the other. If the device is at the end of the communications loop, a terminating resistor must be installed in the second jack (available as part number 00005292).

**Inputs:** 18 - can be configured to ungrounded read thermocouples or end-of-line 0-24 mA (4-20 mA) signals. 0.01 mA resolution.

**Type J:** -150 to 750°C (-238 to 1382°F). 0.1 C (0.2 F) resolution.

**Type K:** -150 to 1180°C (-238 to 2156°F). 0.1 C (0.2 F) resolution.

**Type E:** -150 to 638°C (-238 to 1180°F). 0.1 C (0.2 F) resolution.

**Type T:** -150 to 400°C (-238 to 752°F). 0.1 C (0.2 F) resolution.

### C287 - 4 Analog Inputs - 4 Analog Outputs

**Input Voltage:** 9 to 28 VDC, 3 – 5 watts including 4-20 mA outputs.

**Operating Temperature:** -22 to 158 °F (-30 to 70 °C).

**Storage Temperature:** -22 to 158 °F (-30 to 70 °C).

**Communications:** 1 – RS-485 9600-N-8-1 Communication port.

Connection is made via modular RJ45 Jack. There are two jacks for simple connection to other Comm Series Modules. The user can plug from the master controller into the C287. A second cable can then be run from the other jack to the next Comm Series Module. This can be repeated until the customers I/O resources are satisfied. The last module in the line must have a terminating resistor installed in the second jack (available as part number 00005292).

**Analog Inputs:** 4 - 15-bit true 0-20 mA.

**Analog Outputs:** 4 - 16 bit analogs, software configurable to 0-24 mA, 0-20 mA, or 4-20 mA.

# Display Module Mounting Dimensions



**WARNING: PERFORM THE MOUNTING OPERATION WITH POWER SOURCE OFF. THE MILLENNIUM CONTROLLER MODULE WAS DESIGNED TO BE MOUNTED WITHIN A WEATHERPROOF ENCLOSURE. IT IS INTENDED FOR MOUNTING IN A FLAT PANEL. INSERT THE MODULE FROM THE FRONT SIDE OF THE PANEL AND SECURE THE FOUR MOUNTING SCREWS AND NUTS THROUGH THE**

**Front View**

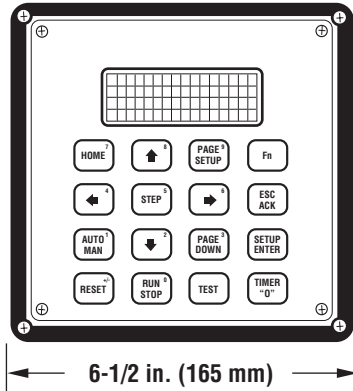

6-1/2 in.  
(165 mm)

6-1/2 in. (165 mm)

**Side View**

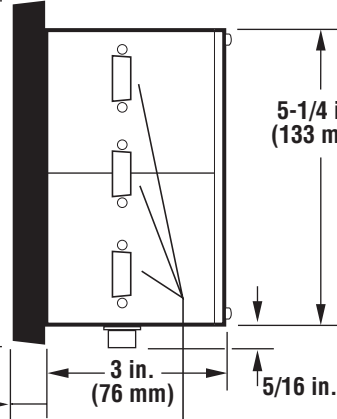

5-1/4 in.  
(133 mm)

3 in.  
(76 mm)

5/16 in. (8 mm)

Each Dsub-9 protudes  
1/16 in. (1.5 mm)

**Back View**

Allow 4-1/2 in. (114 mm)  
for Plug and cable bends radius  
bottom and left side from back.

4-1/2 in.  
(114 mm  
clearance)

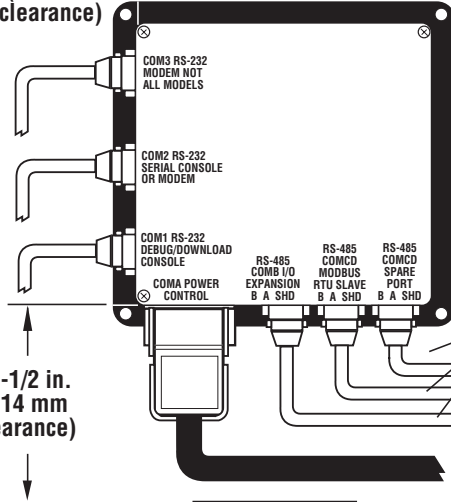

4-1/2 in.  
(114 mm  
clearance)

**NOTE: Use maximum blade width 5/64 in. (2 mm) screwdriver for wire terminals in these plugs. Fastening screws for flanges require 1/8 in. (3 mm) blade screwdriver which can be used for all other screw terminals.**

**Mounting Hole**

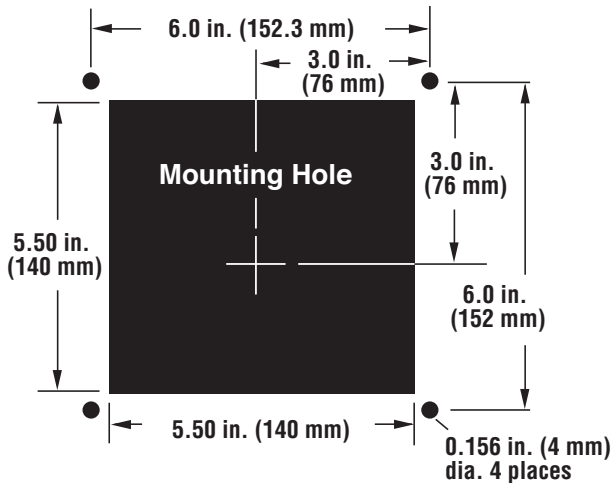

**Side View**

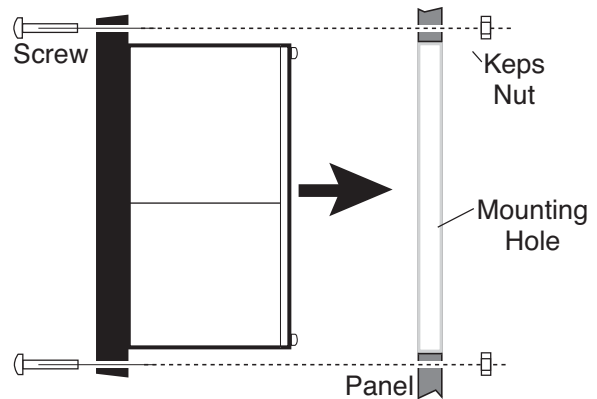

# Power Supply Mounting Dimensions



**WARNING: PERFORM THE MOUNTING OPERATION WITH POWER SOURCE OFF. THE MILLENNIUM CONTROLLER POWER SUPPLY WAS DESIGNED TO BE MOUNTED ON A FLAT PANEL AND WITHIN A WEATHERPROOF ENCLOSURE.**

## Power Supply (Rail mount type.)

The Power Supply has (3) three rail mount clamps for easy panel mounting. Mounting rail is **NOT** supplied. Standard DIN mounting rail models: DIN 46277, EN50035, and EN50022 zinc-plated steel recommended. Recommended length for the mounting rail: 12 inches (305 mm) minimum.

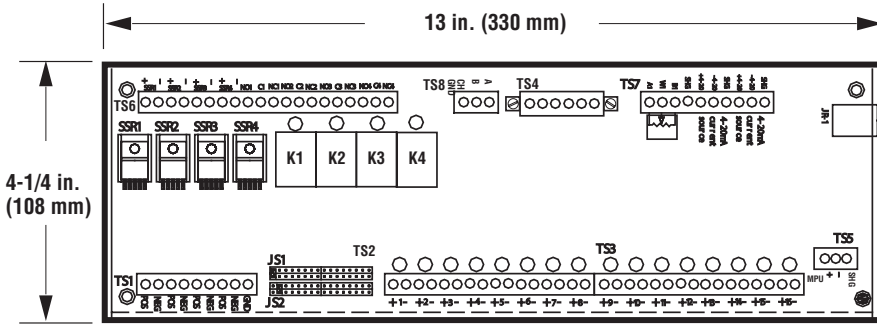

## Side View

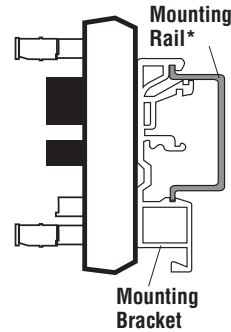

**NOTE:** The maximum screwdriver blade width for wire terminals for plugs TS4 & TS8 is 5/64 in. (2 mm). Mounting flange screws and other terminal block screws use 1/8 in. (3 mm) wide screwdriver blade.

## Side View

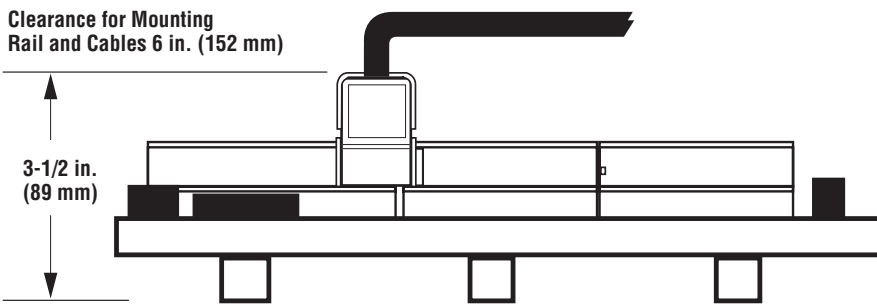

## BRACKET DETAIL

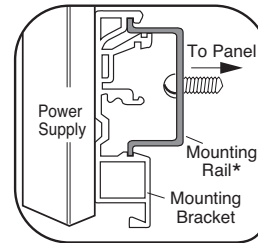

**NOTE:** Mount the MCPS power supply horizontally. If vertical mounting is required, DIN rail clamps must be used to secure the MCPS on the vertical DIN rail.

## MCCP Mounting

### Front View

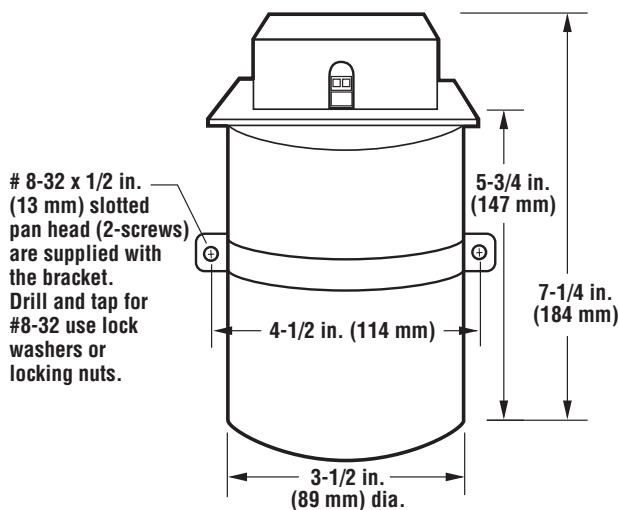

## C267, C277, C287 Mounting

### Front View

### Side View

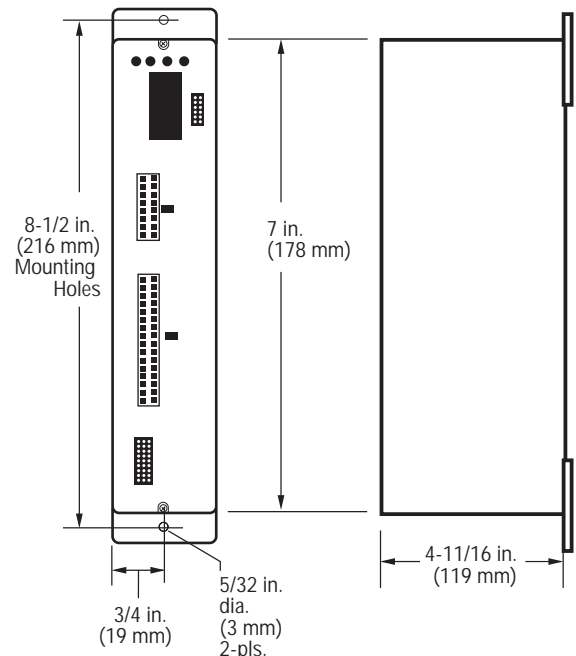

# MC Series Display Module Features and functions

## The Control Module (Head)

The Display/Communications and Control Module or head contains the processing power in the form of a single board computer with support board Vacuum Fluorescent Display (VFD), or optional Liquid Crystal

Display (LCD), both of which are dot matrix alphanumeric displays in a 4-line by 20 character format, and 16-key keypad, emulating a combination of the ten-key pad of a personal computer and a traditional gas compressor panel annunciator.

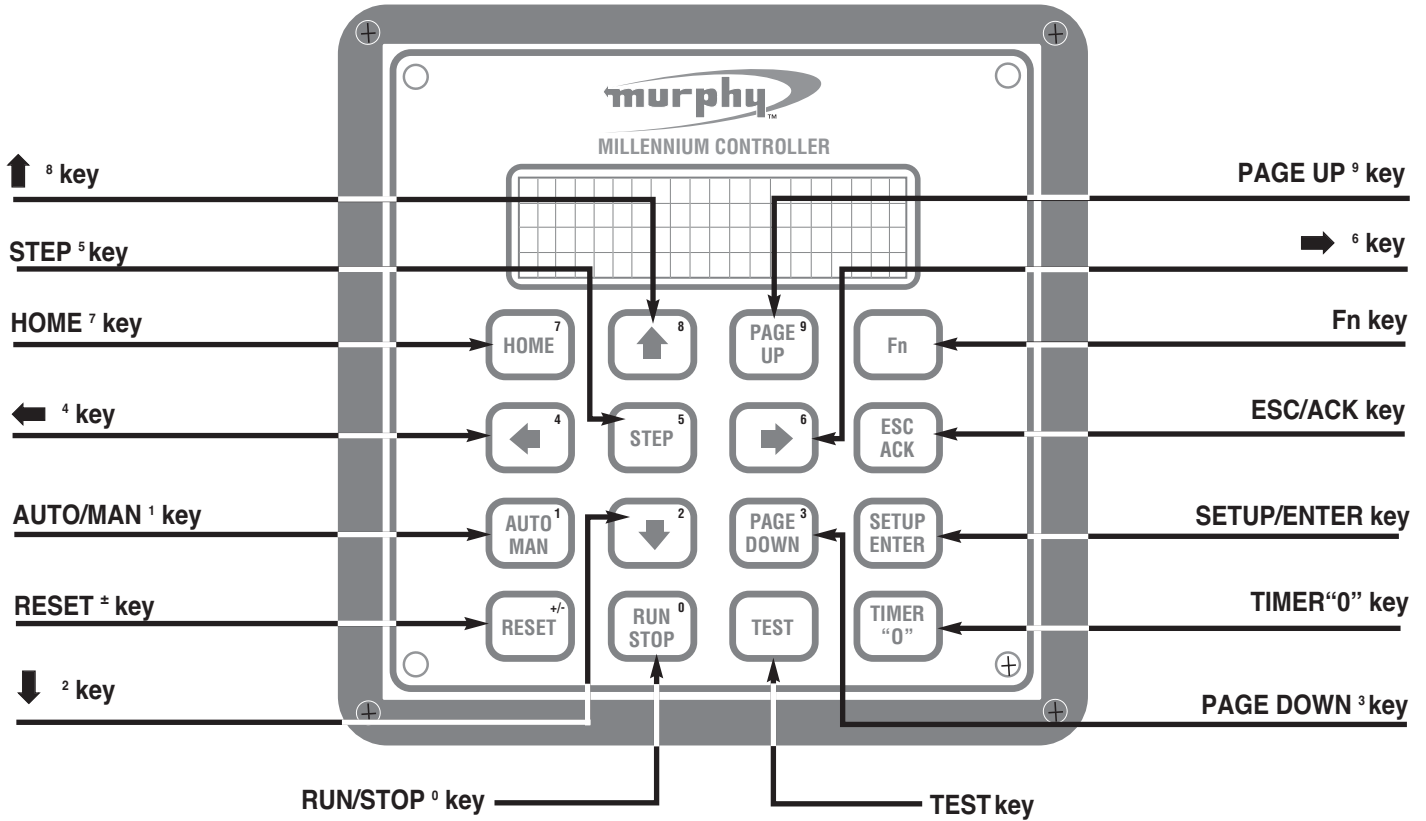

## The Alphanumeric Display (All Models)

The Millennium Controller Display is divided into lines and pages. Up to 100 pages are available in the main displays, setup pages and event pages. Each page can have up to 32 lines. The last page displaying data will be the end page for that display or menu.

It does not necessarily have to be the 100th page.

The same rule applies to the lines of text displayed. The last line displaying data will be the end line (it does not necessarily have to be the 32nd line).

## Typical 1st Page or Home Page

ST:	Normal operation
RPM=xxx	HRS=xx,xxx.x
Ps=xx.x	Pd1=xxx
Pd2=xxx	Pd =xxx

## Typical Last Page

ANALOG OUTPUTS	
ANALOG1	0
ANALOG2	0
DIGITAL POT	0

Pressing

Fn + HOME<sup>7</sup> = Last Page

→<sup>6</sup> = Next Page to the Right

←<sup>4</sup> = Next Page to the Left

# MC Series Display Module Features and Functions

NOTE: The display shows only 4 lines of text at a given page.

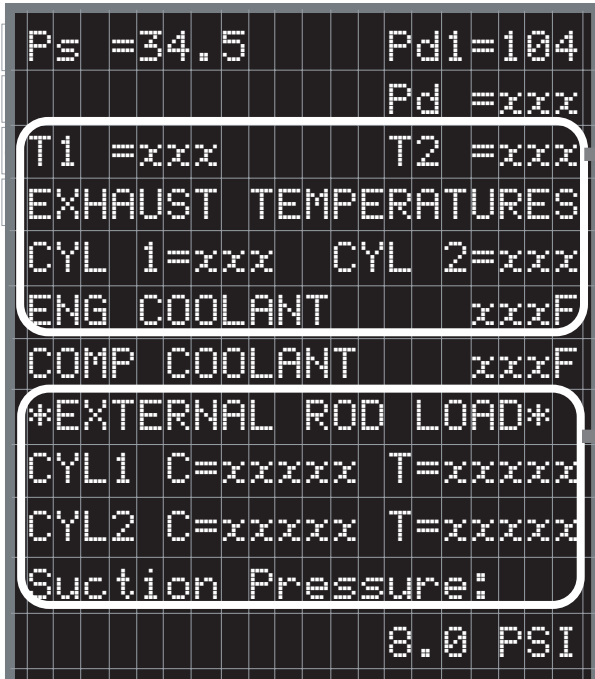

Pressing



The Page Up key allows the user to navigate to the top of the displayed page, 4 lines at a time.

Pressing

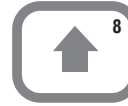

The Up key allows the user to navigate to the top of the displayed page, 1 line at a time.

Pressing



The Page Down key allows the user to navigate to the bottom of the displayed page, 4 lines at a time.

Pressing

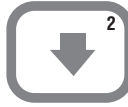

The Down key allows the user to navigate to the bottom of the displayed page, 1 line at a time.













## MC Series Display Module Keys Description

The keys are used to enter numbers while an edit session is active. All key presses can be processed by the application, as defined by the programmer, in addition to their default functions. When the cursor is off, the first key press of any display navigation key will not result in any action except to turn the cursor on. Any key used in controller program function will immediately cause the function on any press of the key. Examples: Reset, Run/Stop, Test, and Timer "0".

	<p>This key has a modified action relative to the current location of the cursor and current page being displayed. Each keypress responds as follows:</p> <ul style="list-style-type: none"> <li>– The display changes to show the top 4 lines of the current page. If already shown then it will change the page to the home page for that menu.</li> <li>– The page is changed to display the Home Page of the 'main' menu.</li> </ul>
	<p>When the Fn Key is pressed before the Home key, the page is changed to display the last page of the current menu.</p>
	<p>The page is changed to display the previous page of the current menu. If no previous page exists, the key will be ignored. This key does nothing at the Home page.</p>
	<p>The page is changed to display the next page of the current menu. If no next page exists, the key will be ignored. The next page is defined while creating the displays in MDesigner. This key moves to the right from the direction of the Home page.</p>
	<p>Navigates the cursor position up, line by line, each key press. If the cursor is positioned at the top of the display, each key press will shift the display down by one line to display a new top line. If the cursor is placed on the top line of the page, the key will be ignored.</p>
	<p>When the Fn Key is pressed before the Arrow Up key, the Autoscroll feature is activated. When Autoscroll is ON, the display will periodically be shifted up, by one line, to display a new bottom line. The period is controlled by the scroll time for each page. When the last line of the page has been displayed, the display will be reset to the first line of the page and begin again.</p>
	<p>Navigates the cursor position down, line by line, each keypress. If the cursor is positioned at the bottom of the display, each keypress will cause the display to be shifted up, by one line, to display a new bottom line. If the cursor is positioned on the last line of the page, the key will be ignored.</p>
	<p>When the Fn Key is pressed before the Arrow Down key, the Autoscroll feature is deactivated. When Autoscroll is OFF, the display is no longer changed automatically.</p>



## MC Series Display Module Key Descriptions *continued*

	<p>Navigates the cursor position up, by four lines, each keypress. The display will be replaced with previous four lines of the page being displayed. If less than four lines are available to be displayed, the cursor will be positioned at the top line of the page. If the cursor is positioned on the top line of the page, the key will be ignored.</p>
	<p>Navigates the cursor position down, by four lines, each keypress. The display will be replaced with the next four lines of the page being displayed. If less than four lines are available to be displayed, the cursor will be positioned at the last line of the page. If the cursor is positioned on the last line of the page, the key will be ignored.</p>
	<p>This key has a modified action relative to the current location of the cursor and the current page being displayed. Each keypress responds as follows:</p> <ul style="list-style-type: none"> <li>– When an edit session is active, it is canceled. Any changes made will be discarded.</li> <li>– When an active event is displayed, if the current login has sufficient rights, the displayed event will be acknowledged.</li> </ul>
	<p>This key has a modified action relative to the current location of the cursor and the current page being displayed. Each keypress responds as follows:</p> <ul style="list-style-type: none"> <li>– When the cursor is positioned on a line that has been designed to allow editing and the current login has sufficient rights, an edit session is activated. The cursor moves from the left to the right side and is placed on top of the parameter to be changed.</li> <li>– When an edit session is active, any changes made will be validated and the controller will be updated if the changes are valid, otherwise they are discarded. The edit session will be ended in either case. The cursor is moved from the right, back to the left side.</li> <li>– When the cursor is positioned on a line that has been designed to navigate to other menus and the current login has sufficient rights to enter the menu, the display will change to show the menu.</li> </ul>
	<p>When the Fn Key is pressed before the Setup/Enter key, SETUP menu is displayed. If this is done while in the settings, nothing happens.</p>
	<p>Use this key to create a combination of keypresses to activate special operations. After the Fn key has been pressed, the top line reads “Fn key activated” and while this is displayed, the second key of the combination can be pressed. The length of time is the “Notify Message Delay” in the administrator settings. If the time expires, the next keypress will operate normally. The primary keys to follow the Fn key are: Home, Setup/Enter.</p>
	<p>This key can be assigned by the programmer, for the application running in the controller. <b>Example:</b></p> <ul style="list-style-type: none"> <li>– The AUTO/MAN key can function as a toggle for the mode of operation in the controller application.</li> <li>– AUTO/MAN is an abbreviation for AUTOMATIC/MANual.</li> </ul>
	<p>This key can be programmed for the application running in the controller. <b>Example:</b> The STEP key can function as a single STEP command for the MANual mode. When the controller is in MANual mode, the STEP key can advance the sequence once for each time it is pressed. If a sequence has finished, it will remain idle until the STEP key is pressed again, to advance it.</p>
	<p>This key has a modified action relative to the current location of the cursor and page displayed. When pressed the RESET key resets a shutdown. It is also used to reset Class B1 and B2 and Test Timers.</p> <p>When the cursor is positioned on a line that is displaying a timer and the current login has sufficient rights, the accumulator for the timer is reset each time the key is pressed, in effect restarting the timer at its preset. With the cursor anywhere except on the B1, B2 and Test Timer line, the function is the same as the TTDJ; if the Test Timer is active, it will reset, otherwise the B1 and B2 timers will reset.</p>
	<p>This key can be programmed for the application running in the controller. <b>Example:</b> Pressing the key will initiate the start (RUN) sequence. Pressing the key again, initiates the shutdown (STOP) sequence. This key is active from any display with one exception. The numeric function key 0 (zero) is active during an edit. Therefore, the operator must exit from the edit session (ESC), to operate the key normally.</p>
	<p>This key can be assigned by the programmer, for the application running in the controller. <b>Example:</b> Pressing this key will initiate the TEST mode. Once the TEST mode is activated, the TEST key can be pressed again, to end the mode.</p>
	<p>This key has a modified action relative to the current location of the cursor and page displayed. Each keypress responds as follows:</p> <ul style="list-style-type: none"> <li>– When the cursor is positioned on a line that is displaying a timer and the current login has sufficient rights, the accumulator for the timer is set to zero, in effect ending the timer as if it had timed out normally. With the cursor anywhere except on the B1, B2, or the Test Timer lines, the function is the same as the TTDJ; if the Test Timer is active, it will be zeroed. Otherwise if the B1 and B2 Timers are active, first the B1 Timer is zeroed and next the B2 Timer is zeroed.</li> <li>– When an edit session is active, any changes made will be removed, clearing and restarting the session, which remains activated.</li> </ul>

# MC Series I/O Matrix

	DI	4-20mA/0-5 VDC/ Sender/ DI	4-20mA/ TC/ AI	4-20mA AI	FET DO	Relay DO	4-20mA AO	Freq. IN	PS Mon
C267	8	7			8			1	1
C267NOAI	15				8			1	1
C277			18						
C287				4			4		
MCPS	16				4	4	2	1	
4X C277			72						
MCPS	16				4	4	2	1	
4X C267	32	28			32			4	4
4XC267NOAI	60				32			4	4
MCPS	16				4	4	2	1	
4X C287				16			16		
MCPS	16				4	4	2	1	
3X C277			54						
C267	8				8			1	1
C267NOAI	15				8			1	1
MCPS	16				4	4	2	1	
3X C277			54						
C287				4			4		
MCPS	16				4	4	2	1	
3X C267	24	21			24			3	3
3XC267NOAI	45				24			3	3
C287				4			4		
3X C267	16				4	4	2	1	
3X C267	24	21			24			3	3
3XC267NOAI	45				24			3	3
C277			18						
3X C267	16				4	4	2	1	
3X C287				12			12		
C277			18						
MCPS	16				4	4	2	1	
3X C287				12			12		
C267	8	7			8			1	1
C267NOAI	15				8			1	1
MCPS	16				4	4	2	1	
2X C277			36						
2X C267	16	14			16			2	2
2XC267NOAI	30				16			2	2
MCPS	16				4	4	2	1	
2X C277			36						
C287				8			8		
MCPS	16				4	4	2	1	
2X C267	16	14			16			2	2
2XC267NOAI	30				16			2	2
2X C287			36						
MCPS	16				4	4	2	1	
2X C277			36						
C287				4			4		
C267	8	7			8			1	1
C267NOAI	15				8			1	1
MCPS	16				4	4	2	1	
C277			18						
C287				4			4		
2XC267	16	14			16			2	2
2XC267NOAI	30				16			2	2
MCPS	16				4	4	2	1	
C277			18						
2X C287				8			8		
C267	8	7			8			1	1
C267NOAI	15				8			1	1
MCPS	16				4	4	2	1	



# C267 Model Expansion Module

## C267 Model (0004923)

8 Discrete Inputs - 7 Analog Inputs - 8 Discrete Outputs - 1 Frequency Input

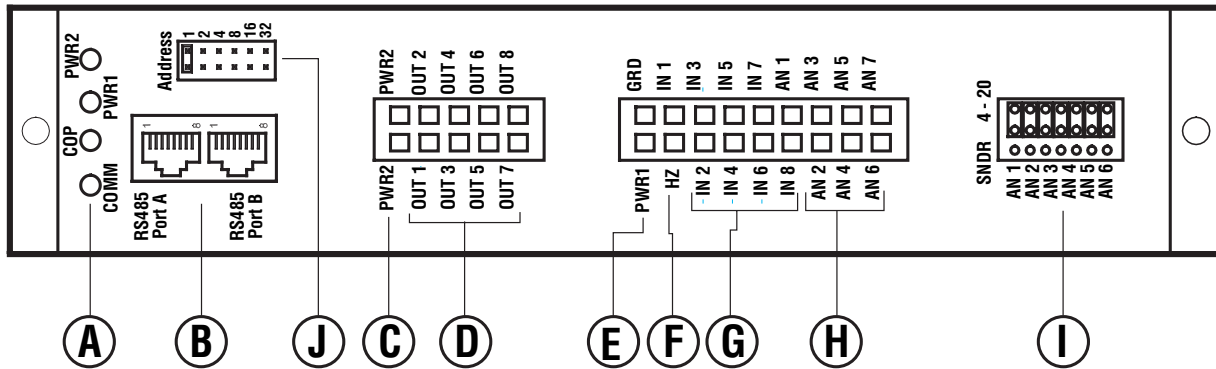

### C267 Expansion Module Components

A. **Status LED's:** There are four Status LED's on the C267.

- **COMM** stands for Communication. It will flash any time a communication packet passes to or from the C267.
- **COP** stands for Controller Operating Properly. It will flash every quarter second if the internal CPU is functioning properly. This light should start flashing as soon as power is supplied to the PWR1 connection.
- **PWR1** stands for Power 1. This light will turn on when power is properly applied to the Pins PWR1 and GND. This is the control power.
- **PWR2** stands for Power 2. This light will turn on when power is properly applied to the PWR2 and GND pins. This is the battery plus power for the FET outputs. Note: Both PWR2 pins should be connected to increase the amperage capability of the outputs.

B. **RS-485 Communication Port:** Port A and Port B are electrically common, for wiring convenience. If more than one module is used, you can bring your patch cable into Port A and then connect from Port B to the next module. Note: The last module in the communication chain must have a terminating resistor module.

C. **Power 2:** This is the battery plus power for the FET outputs. Note: Both PWR2 pins should be connected to increase the amperage capability of the outputs.

D. **Output Connections:** OUT1 through OUT8 are the controller output connections. Each output supplies battery plus at 5 amps. Please note: The maximum current draw for the unit is 18 amps when both PWR2 pins are connected.

E. **Control Power 1:** Connect PWR1 to battery (+) and GRD to battery (-). This supplies power to the control portion of the circuitry.

F. **Frequency Input:** This input is used to sense frequency via a magnetic pickup.

G. **Digital Inputs:** IN1 through IN8 are optically isolated digital inputs for use with ground or battery plus digital switches.

H. **Analog Inputs:** AN1 through AN7 are 8-bit analog inputs that can be shunt selected to read 0-5 VDC, 4-20 mA, and/or resistive electric gauge sending units. Each analog can be individually selected for any one of the three types of inputs.

I. **Analog Selector Shunts:** These shunts are used to configure what type of end device is being used to supply the analog signal for each analog channel. To select 4-20 mA, place the shunt on top two pins. To select electric gauge sending unit, place the shunt on the bottom two pins. To select 0-5 VDC, remove the shunt from the channel.

J. **Modbus Address Select Shunts:** These shunts allow you to assign a unique address to each C267 that may be in the system. This allows the master controller to differentiate between the modules. For example, to name the controller address 21, place the shunts on LK1, LK4, and LK16 ( $1 + 4 + 16 = 21$ ).

## C277 Model (0007620)

18 Thermocouples or 4 - 20 mA Inputs

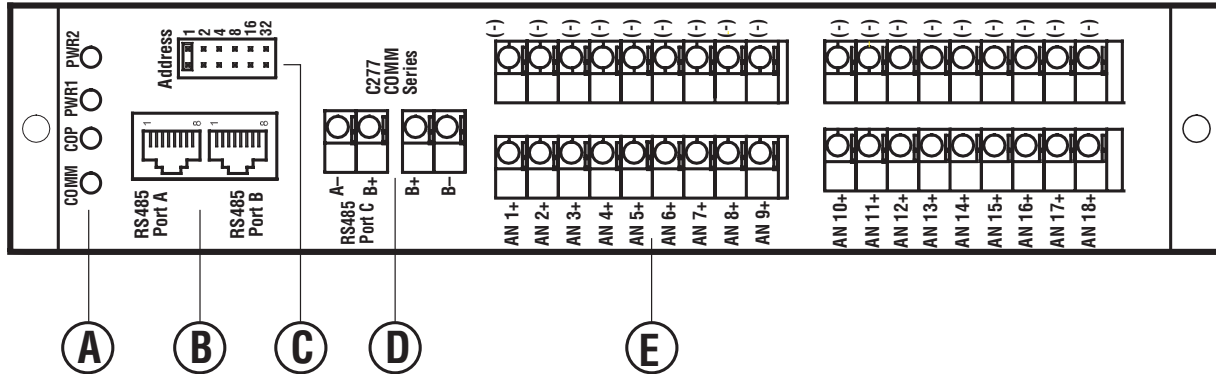

### C277 Expansion Module Components

**POWER UP NOTE:** Due to the high accuracy of the readings provided by the C277, a great deal of averaging will be processed at power-on. If all 18 channels are active, up to 48 seconds are needed to reach full accuracy. Delay configuring or polling the C277 for 8 seconds on power-up. Once this initial power-up sequence is complete, each complete update takes about 2 seconds with a filter frequency of 120.

- A. **Status LED's:** There are four Status LED's on the C277.
  - **COMM** stands for Communication. It will flash any time a communication packet passes to or from the C277.
  - **COP** stands for Controller Operating Properly. It will flash every quarter second if the internal CPU is functioning properly. This light should start flashing as soon as power is supplied to the PWR1 connection.
  - **PWR1** stands for Power 1. This light will turn on when power is properly applied to the Pins PWR1 and GND. This is the control power.
  - **PWR2** stands for Power 2. This light will turn on when the internal (minus) 5 VDC supply is functioning properly.
- B. **RS-485 Communication Port:** Port A, Port B and Port C are electrically common, for wiring convenience. If more than one module is used, you can bring your patch cable into Port A and then connect from Port B to the next module. Port C is available for twisted pair cable connections.  
 Note: The last module in the communication chain must have a terminating resistor module.
- C. **Modbus Address Select Shunts:** These shunts allow you to assign a unique address to each C277 that may be in the system. This allows the master controller to differentiate between the modules. For example, to name the controller address 21, place the shunts on LK1, LK4, and LK16 ( $1+4+16 = 21$ ).
- D. **Control Power Terminals:** Hook battery (+) to the terminal labeled B+. Hook battery (-) to terminal labeled B-.
- E. **Channel Connection Terminals:** Each channel has two dedicated terminals. The top row is the negative side of the connection and the bottom row is the positive side of the connection.

## C287 Model (0005945)

4 Analog Inputs - 4 Analog Outputs

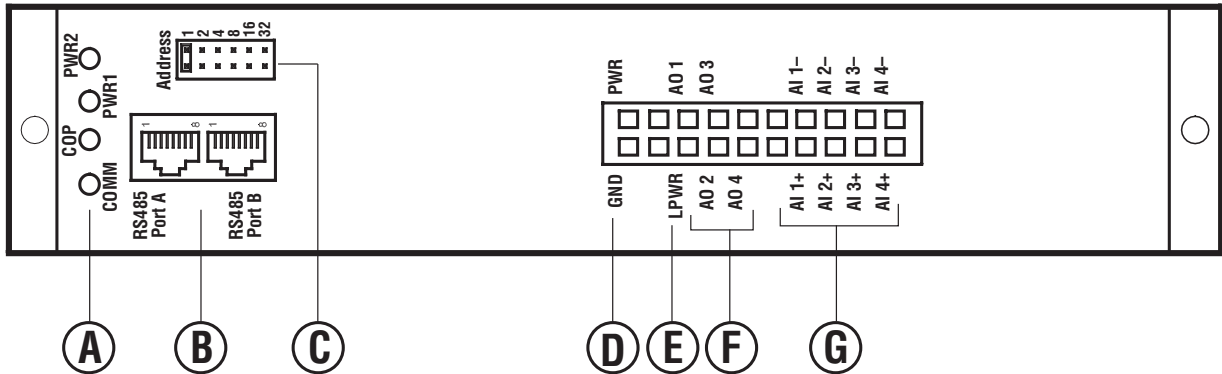

### C287 Designation

A. **Status LED's:** There are four Status LED's on the C287.

- **COMM** stands for Communication. It will flash any time a communication packet passes to or from the C287.
- **COP** stands for Controller Operating Properly. It will flash every half-second if the internal CPU is functioning properly. This light should start flashing as soon as power is supplied to the PWR connection.
- **PWR1** stands for Power 1. This light will turn on when power is properly applied to the Pins PWR1 and GND. This is the control power.
- **PWR2** stands for Power 2. This light will turn on when the internal +/- 15 VDC power is functioning properly.

B. **RS-485 Communication Port:** Port A and Port B are electrically common, for wiring convenience. If more than one module is used, you can bring your patch cable into Port A and then connect from Port B to the next module. Note: The last module in the communication chain must have a terminating resistor module.

C. **Modbus Address Select Shunts:** These shunts allow you to assign a unique address to each C287 that may be in the system. This allows the master controller to differentiate between the modules. For example, to name the controller address 21, place the shunts on LK1, LK4, and LK16 ( $1 + 4 + 16 = 21$ ).

D. **Control Power:** Hook battery (+) to PWR and battery (-) to GND. This supplies power to unit.

E. **Analog Loop Power:** Hook the analog Loop Power to this input.

F. **Analog Outputs:** These pins supply the 4-20 mA output current.

G. **Analog Inputs:** When used as the last unit on an analog loop, ground the AN(-) pin and hook the output from the transmitter to the AN(+) pin. When used in a loop, bring the output from the transmitter into the AN(+) pin and come out of the AN(-) pin to the next device.

# Typical MCPS Power Supply Wiring Diagram

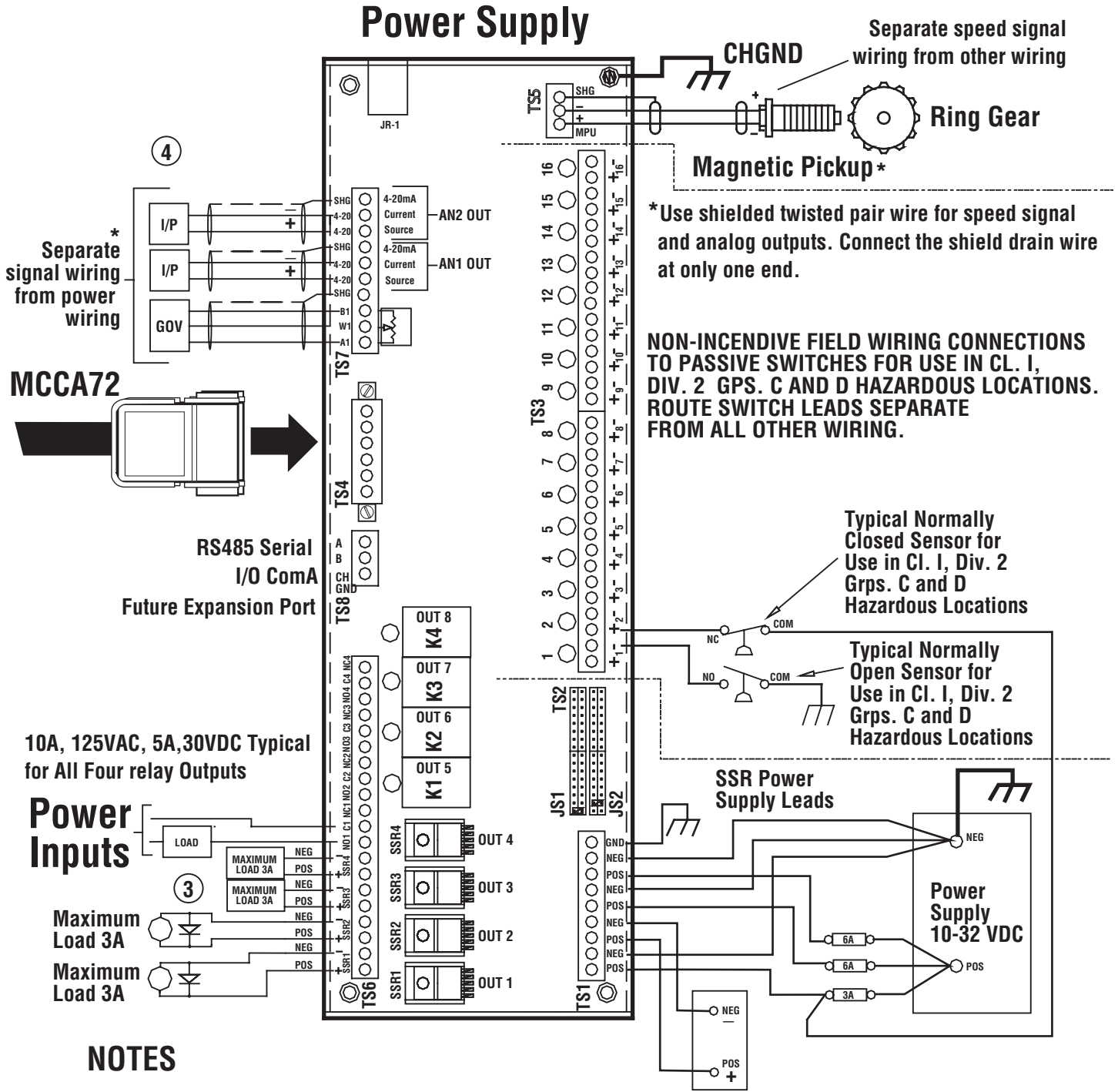

4  
Separate signal wiring from power wiring

MCCA72

RS485 Serial I/O ComA Future Expansion Port

10A, 125VAC, 5A, 30VDC Typical for All Four relay Outputs

Power Inputs

Maximum Load 3A  
Maximum Load 3A

## NOTES

- Field Wiring connections to be installed in accordance with the NEC for Class I, Div. 2, Grps. C and D Hazardous Locations.
- Install separate conductors for SSR and controller power input. Allow for conductor voltage drop when determining conductor size. All power supplies must have common ground.
- For an inductive load, install a diode in parallel with the load. Use a fast recovery 3A, 50 PIV diode. Mount diode as close as possible to the load device. maximum load inductance: 1H @ 0.25A, 5mH @ 3A.
- $RI = (Vps - 3.15)/0.20$   
RI = Loop Resistance  
Vps = Power Supply Volts
- Sensor Switch Input Current: 2.45 MA max @ 10VDC, 9.2MA @32VDC
- Minimum charge/discharge cycle time 5 min.

Separate speed signal wiring from other wiring  
CHGND  
Magnetic Pickup\*  
Ring Gear

\*Use shielded twisted pair wire for speed signal and analog outputs. Connect the shield drain wire at only one end.

NON-INCENDIVE FIELD WIRING CONNECTIONS TO PASSIVE SWITCHES FOR USE IN CL. I, DIV. 2 GPS. C AND D HAZARDOUS LOCATIONS. ROUTE SWITCH LEADS SEPARATE FROM ALL OTHER WIRING.

Typical Normally Closed Sensor for Use in Cl. I, Div. 2 Grps. C and D Hazardous Locations

Typical Normally Open Sensor for Use in Cl. I, Div. 2 Grps. C and D Hazardous Locations

SSR Power Supply Leads

Power Supply 10-32 VDC

Stored Energy Source (MCCP) See Note 6.

**WARNING**  
EXPLOSION HAZARD - DO NOT DISCONNECT EQUIPMENT UNLESS POWER HAS BEEN SWITCHED OFF OR THE AREA IS KNOWN TO BE NON-HAZARDOUS.



# Typical C267 Module Wiring

## Expansion Module C267 Model (0004923)

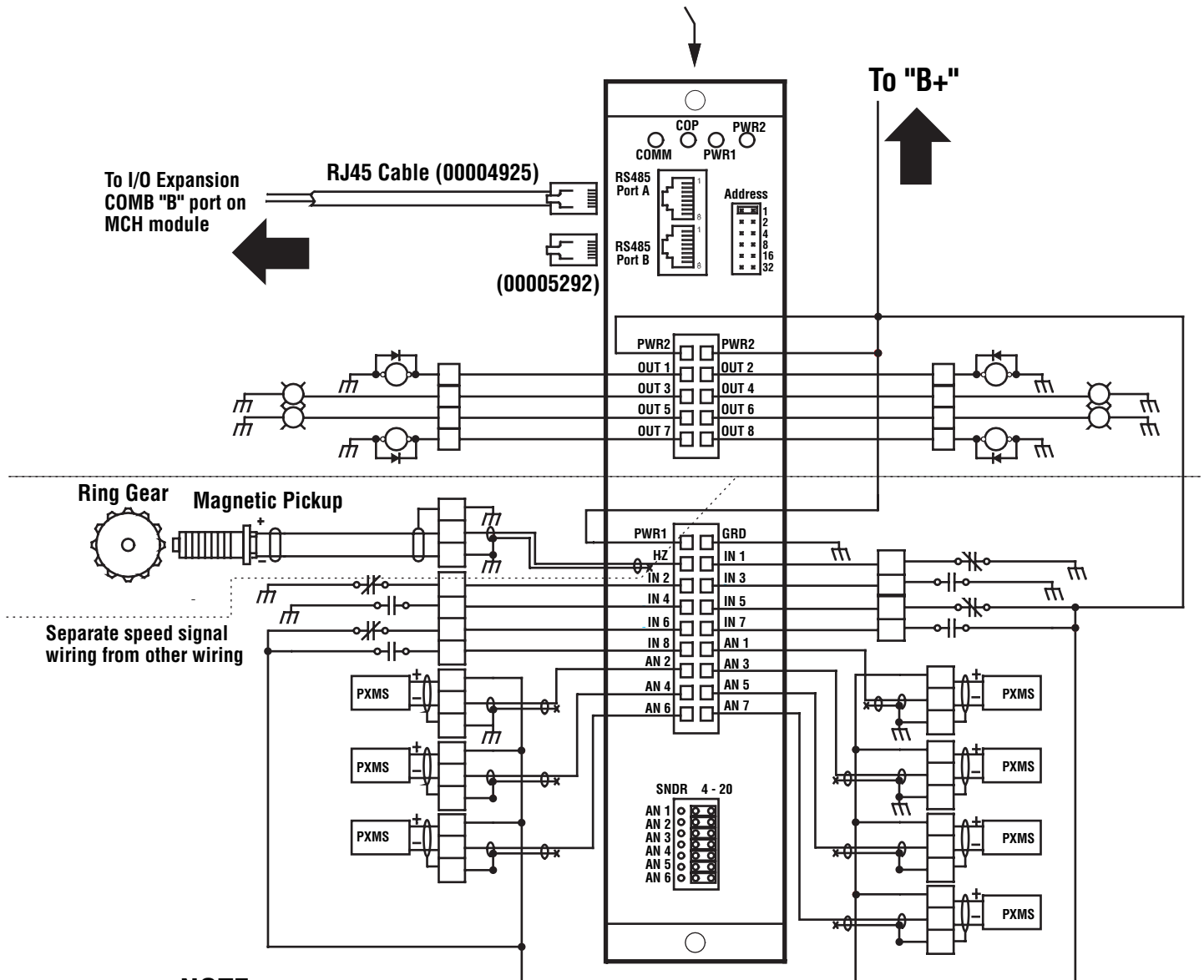

### NOTE:

□ = Screw terminal block

- Vertical mounting is suggested - Harnesses are available.
- Use Molex crimp pins 39000039 (Murphy 00007181).
- Use crimper specifically designed for these Molex pins.
- Separate signal wiring from power and output wiring.
- Use shielded twisted pair cable for 4-20 mA/Transmitter/Speed signal wiring.
- Connect shield drain wire to ground of the device reading the signal, only.



# Typical C267 Module Wiring Using C267TBIF

## Expansion Module C267 Model (0004923) To Interface Module C267TBIF (0007719)

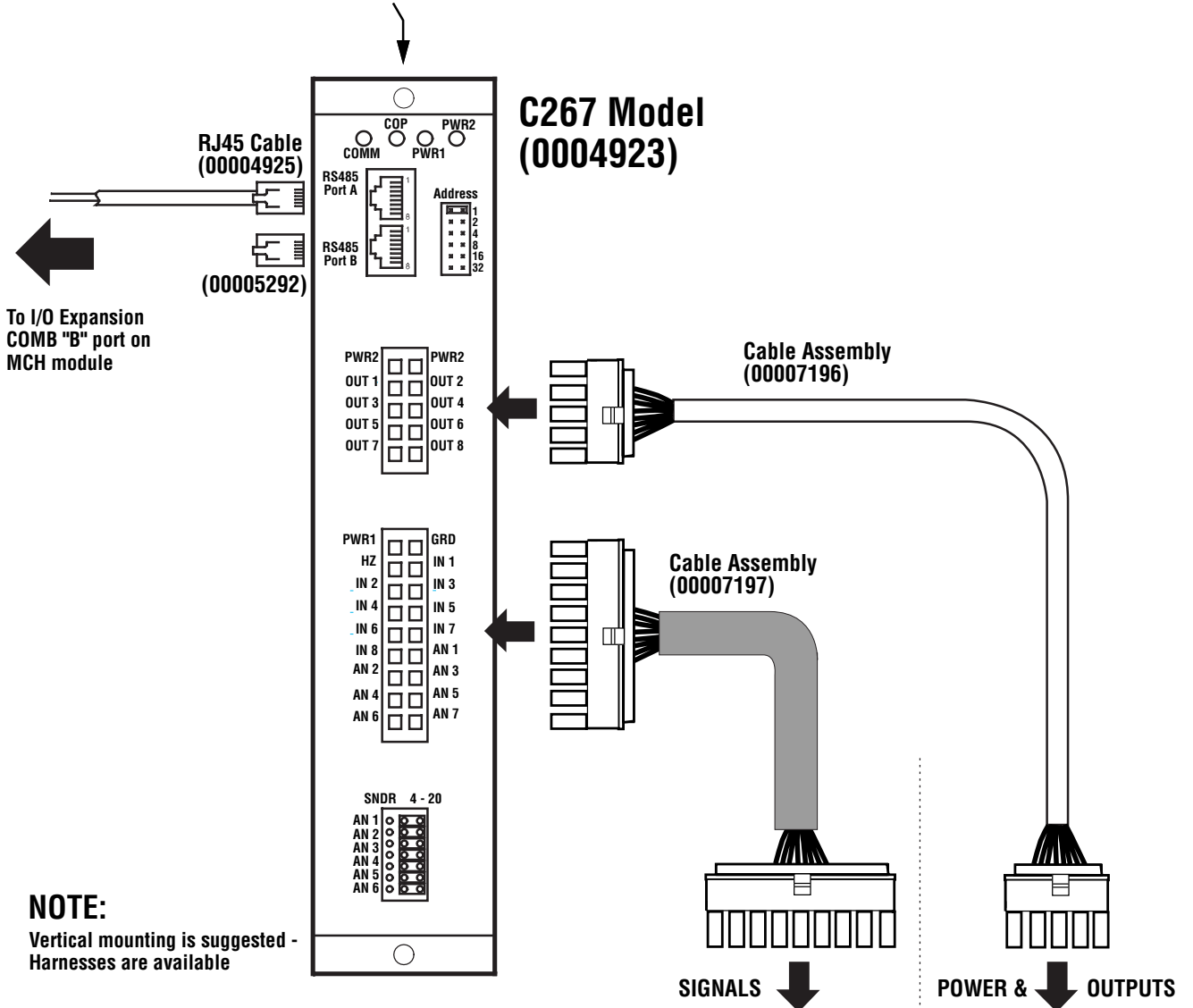

\* Use shielded twisted pair cable with shielded drain wire connected at the EMSTBIF end only.

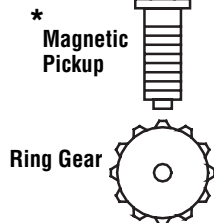

# Typical C277 Module Wiring

## Expansion Module C277 Model (0007620)

Vertical mounting is suggested -  
Harnesses are available

For best accuracy group thermocouple inputs from the middle channels, 9 and 10. Locate 4 - 20 mA channels at the first and last channels.

To I/O Expansion  
COMB "B" port on  
MCH module

RJ45 Cable  
(00004925)  
  
(00005292)

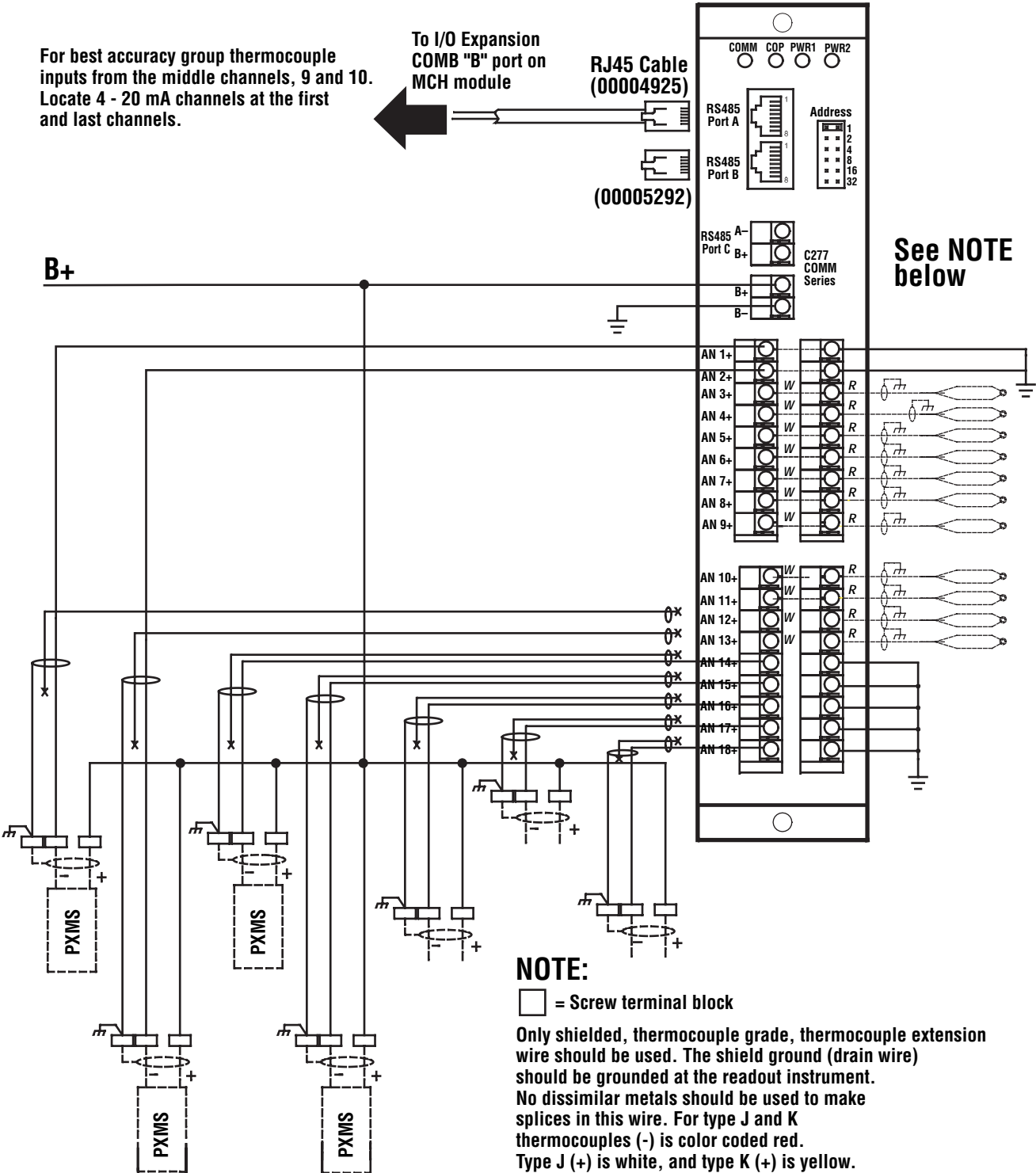

See NOTE below

### NOTE:

- = Screw terminal block
- Only shielded, thermocouple grade, thermocouple extension wire should be used. The shield ground (drain wire) should be grounded at the readout instrument.
- No dissimilar metals should be used to make splices in this wire. For type J and K thermocouples (-) is color coded red.
- Type J (+) is white, and type K (+) is yellow.
- For other types consult a thermocouple reference book.
- Pressure transmitters should be wired using shielded twisted pair cabling.
- Do not use grounded thermocouples.

# Typical C287 Module Wiring

## Expansion Module C287 Model (0005945)

Vertical mounting is suggested

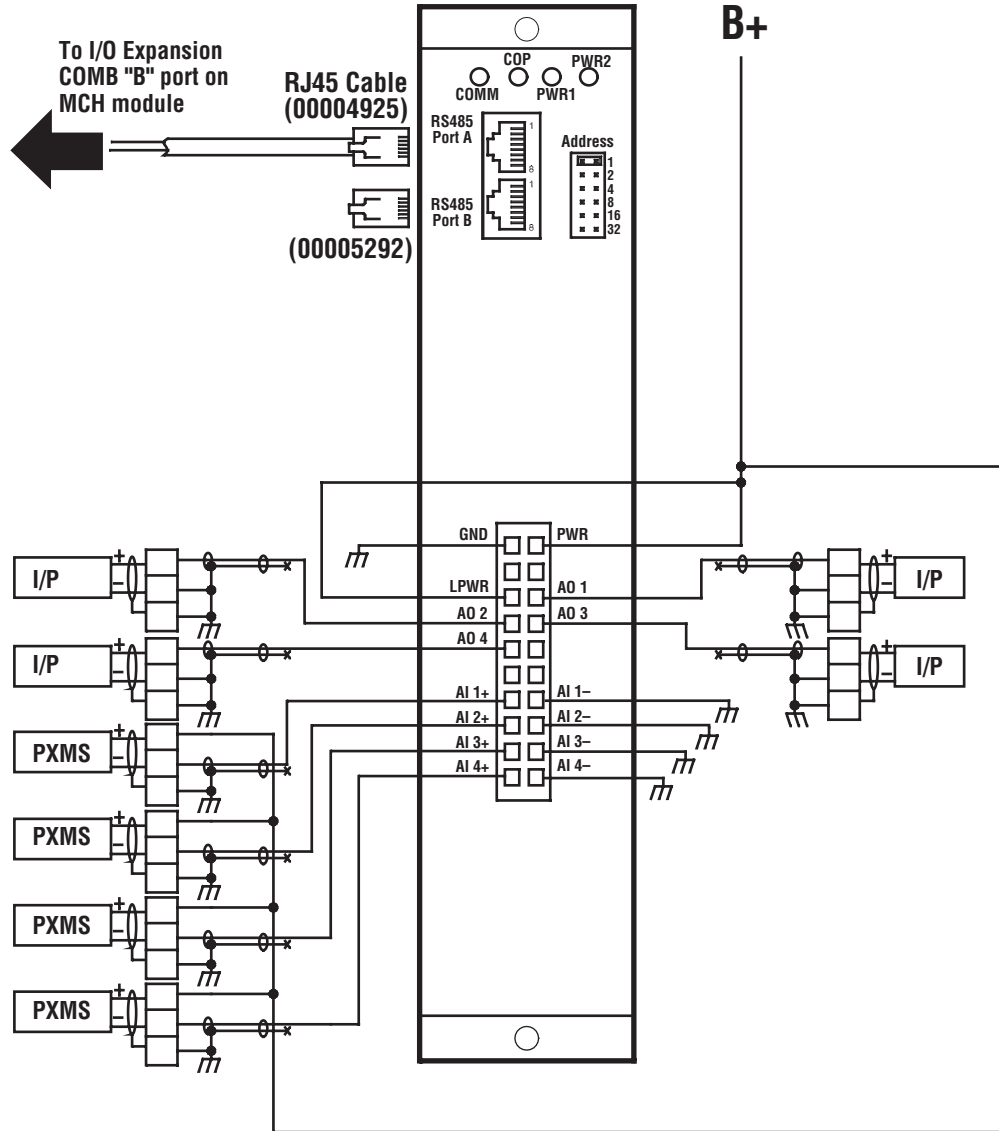

### NOTE:

□ = Screw terminal block

- Vertical mounting is suggested - Harnesses are available.
- Use Molex crimp pins 39000039 (Murphy 00007181).
- Use crimper specifically designed for these Molex pins.
- Use shielded twisted pair cable for 4-20 mA/Transmitter/any Analog Input & Output.

# Millennium Controller Basic Instructions

## MCH Module Basic Instructions

Turn power on to the MCPS power supply. After approximately 20 seconds the first display appears. The following screens are "typical". Actual screens depend on the program used by the controller.

Press HOME key To Get to The Home Screen  
May need to pressed more than once, depending on cursor position.

```

ST:  READY TO START
RPM=      0  HRS=      0.0
Ps  =  0.0  Pd1=      0
                Pd2=      0
    
```

To Start the Unit ( from HOME SCREEN)  
Press "**RESET**" then "**RUN STOP**". The display below will be shown and the unit will proceed to the Warmup mode.

```

ST:  START COMMITTED
RPM=      0  HRS=      0.0
Ps  =  0.0  Pd1=      0
                Pd2=      0
    
```

To Reset a Shutdown  
To reset a shutdown condition press "**RESET**". The display below shows a typical shutdown screen. To leave these screens, press a navigation key. If more than one shutdown occurs, the display will cycle displaying the Events (1 of 2, etc.).

```

Event J      1 of 1
02:01:52PM  04JAN01
Shtdn: 1st Discharge
Hi Scrubber Liq Lvl.
    
```

```

ST:  READY TO START
RPM=      0  HRS=      0.0
Ps  =  0.0  Pd1=      0
                Pd2=      0
    
```

To See Class B1, B2 & Test Timers press "**RIGHT** Arrow Key"

```

ST:  Running
10/19/01  B1=      0sec
18:58    B2=      0sec
Test:Off  Test=300sec
    
```

To Reset Class B1 Timer in Timer Screen  
Use "**DOWN**" key to get to the B1 TIMER line. Press "**RESET**":

```

ST:  Running
10/19/01  B1=  300sec
18:58    B2=      0sec
Test:Off  Test=300sec
    
```

To Zero Class B1 Timer in Timer Screen  
With Cursor on B1 Timer line, Press "**TIMER** "0".

```

ST:  Running
10/19/01  B1=      0sec
18:58    B2=      0sec
Test:Off  Test=300sec
    
```

To Reset Class B2 Timer in Timer Screen  
Use "**DOWN**" key to move to the B2 TIMER line.  
Press "**RESET**" key.

```

ST:  Running
10/19/01  B1=      0sec
18:58    B2=  600sec
Test:Off  Test=300sec
    
```

To Zero Class B2 Timer in Timer Screen  
With Cursor on B2 Timer line, Press "**TIMER** "0".

```

ST:  Running
10/19/01  B1=      0sec
18:58    B2=      0sec
Test:Off  Test=300sec
    
```

Alternatively, from any screen, pressing the "**RESET**" key will reset both the B1 and B2 Timers. With both Timers active, one press of "TIMER "0" will zero the B1 Timer and the next press of "TIMER "0" will zero the B2 Timer. Also, from any screen the "TEST MODE" can be initiated and the "TEST" timer zeroed.

To Enter Test Mode Press "**TEST**" key.

To View Test Timer Seconds Left  
From the Home screen, press "**RIGHT ARROW**" to get to the Timer Screen and view the Test Timer Value.

```

ST:  Running
10/19/01  B1=      0sec
18:58    B2=      0sec
Test:On   Test=298sec
    
```

To Reset and Zero Test Timer in Timer Screen  
Move Cursor down to Test Timer line and press the "**RESET**" key. The Test Timer will be reset to a standard value of 300 seconds. Press the **TIMER** "0" key to zero the test timer.

```

ST:  Running
10/19/01  B1=      0sec
18:58    B2=      0sec
Test:Off  Test=300sec
    
```

Press "**RESET**" to reset a shutdown while in Test.

# MCH Power Up and Self Test Description

## Definitions

**Application** – A program written with ISaGRAF that does the functional control that is downloaded to the Millennium Controller using a PC and the ISaGRAF software.

**Project** – The result of MDesigner screen creation and configuration software which is downloaded using MDesigner software.

**Login** – The line that has this is the line where different levels of privileges are granted based on the pass code used, and the resulting Login level. Login level (5) does not require a code, and is the level when there is not a higher level Login present. To Login with a higher level code, the cursor must be placed on this line, and then the ENTER key must be pressed. The cursor will move over the zero displayed on the right side of that line. A code can now be entered. There are (4) levels of code, going from level (4), the lowest level of privilege up to level (1), the highest level of privilege. Level (1) is called the Administrator level, and the privileges are all encompassing. There is nothing that cannot be done with the Administrator code. The lower levels have different privileges. For example, level (4), some settings are available to be changed that cannot cause improper operation of the machinery. Level (3) is a level where there should be set points that could cause improper operation of the machine, and not everybody should have access to those. Level (2) is a level where calibration of inputs can be done, and is for higher level trained technicians. At the Administrator level, level (1), the Project, and/or Application can be deleted, outputs can be forced off and on, a Remote Debugger can be run, the administrator menu is available, and the real time clock can be set. All login levels have a common timer that starts to count down after each key press. If there are no key presses for the length of the Inactive/AutoLogout Delay, then the Login level will revert back to level (5).

## MCH Module Power Up and Self Test

Turn on the power to the MCPS power supply. There will be about 20 seconds before the display first shows:

```

□      Millennium
      KERNEL v0.96
      PWRSPPLY v1.7
Press SETUP for Menu
    
```

The above screen will be present for about 6 seconds after initial power-up and boot-up. If SETUP is pressed and there is an application and project present, the Setup screen will be shown as:

```

*      Setup Menu      *
Login (5)              0
Enable Transfer
Remove Application
    
```

```

Remove Project
Run Factory Test
Run Remote Debugger
Enable Debug Mode
    
```

```

Set Date & Time
Kernal                U0.96
Powerup               U1.76
PowerSupply           U1.7
    
```

If there is no application or project, the "Login" line and the two "Remove" lines will be missing. If there is no application, but there is a project, only the "Remove Application" line will be missing. If there is no project, but there is an application, only the "Remove Project" line will be missing.

If SETUP is not pressed and there is no project, or no project and no application, this screen will show next:

```

Project Not Detected
Enable Transfer
To download with
MDesigner
    
```

Pressing ESC / ACK (Escape) will go back to the Setup Menu to allow Setup Menu selections, such as "Enable Transfer".

If SETUP is not pressed and there is a project, but no application, this screen will show:

```

No Application
Detected
Link with ISaGRAF
To download
    
```

This screen will be the only screen available until there is a download from ISaGRAF.

If there is a project and a successful download has been done from ISaGRAF, then the application will start.

## Remove Application

If "Remove Application" is chosen, the screen will show:

```

*Remove Application*
Are you sure?
ESC=NO      ENTER=YES
    
```

Only choose "Yes" if a PC running ISaGRAF is connected and ready to download a new, or revised application. If "Yes" is chosen, the application will be removed and the display will show the setup menu again.

Set up can be exited by allowing the time to run out, or by pressing "ESC" (Escape), either way the display will show:

```

No Application
Detected
Link with ISaGRAF
To download
    
```

✧ = Only present within Administrator Login, Level 1.

# MCH Power Up and Self Test Description *continued*

## Remove Project

If "Remove Project" is chosen, the screen will show:

```
* Remove Project *
Are you sure?
ESC=NO ENTER=YES
```

Only choose "Yes" if a PC running MDesigner software is connected. If "Yes" is chosen, the second line of the display will change to the following screen:

```
* Remove Project *
* Deleting Project *
```

When that is complete, the display will show:

```
Project Not Detected
Enable Transfer
To download with
MDesigner
```

From this display press "ESC" (escape) to return to Setup Menu.

## Enable Transfer

From the Setup Menu, if "Enable Transfer" is chosen, the screen shows:

```
Millennium
Enable Transfer in
MDesigner
Scanning COM1
```

With MDesigner running with a project loaded, choose download, and the screen will show:

```
Millennium
Download in Progress
Receiving...
```

Then the bottom line will change to:

```
Millennium
Download in Progress
Decompressing...
```

Once the Project has been downloaded, the Setup Menu screen returns.

```
Millennium
Initializing
Please Standby
```

## Run Factory Test

To run the "Factory Test", two special cables are needed for the communications tests to pass. Without the cables, the keypad and the display can be tested. Here is the test procedure assuming the jumper cables have been plugged into the COMB and COMC ports, and COM1 and COM2 ports.

Using the DOWN ARROW key, position the cursor on the Run Factory Test line.

Press SETUP/ENTER. The controller will exit the Setup Menu.

The Test will briefly display the version information as shown:

```
* Test I/O v1.2 *
* by FWMurphy *
* Preparing *
* to Test *
```

Next the display will change and wait for a key from the keypad to be depressed to begin the test, as shown next:

```
*****
* Press any Key *
* to Begin *
*****
```

Press any key, and the display will show:

```
Communications
Checking P1 to P2
DATA LINE
????????????????
```

If each of the communications tests pass, the next test will automatically execute. While the test is in process, the bottom line will be all "?". If it passes, the bottom line will display "PASSED" briefly before moving to the next test. If it fails, the bottom line will display "FAILED". At that time, it should be noted on paper which test failed and then any key can be pressed to execute the next test. The tests in order are:

- P1 to P2 DATA LINE
- P2 to P1 DATA LINE
- P2 to P1 CTS TEST





# MC Series Standard Displays - Typical Snapshot

```

*FAULT SNAPSHOT
Time  xx:xx   Date 7/19
Speed:  xxxRPM
    
```

```

*****OIL FLOW*****
Eng Total  xxxPts
Comp Total  xxxPts
    
```

```

*****PRESSURES*****
Suction  xxPSI
1st Disch  xxPSI
2nd Disch  xxPSI
    
```

```

Disch  xxxPSI
    
```

```

***TEMPERATURES***
Cyl#1 Disc:  xxxF
Cyl#2 Disc:  xxxF
Cyl#3 Disc:  xxxF
    
```

```

Cyl#1 Exhaust:  xxxF
Cyl#2 Exhaust:  xxxF
Cyl#3 Exhaust:  xxxF
Cyl#4 Exhaust:  xxxF
    
```

```

Eng. Jkt. Wtr.  xxxF
Comp. Jkt. Wtr.  xxxF
Air Manifold  xxxF
Suction  xxxF
    
```

```

***ROD LOAD***
Cyl#1 CMP: xxxxxLbs
      TEN: xxxxxLbs
Cyl#2 CMP: xxxxxLbs
    
```

```

      TEN: xxxxxLbs
Cyl#3 CMP: xxxxxLbs
      TEN: xxxxxLbs
    
```

# MC Series Standard Display Menus

## Setup Menu

This is what the typical Setup Menu looks like. The setup menu is the starting point to log into other screens.

```
*      SETUP MENU      *
Login(5)                0
Event List
Process Setpoints
```

```
Administrator Menu
Clear Event List
Set Date & Time
Force Menu
```

```
ACT Login(5) 4 of 34
07:06:49AM 26Jun2001
Shdn:Compressor
Hi Coolant Temp
```

To access the settings, first press Fn, and then quickly press Setup/Enter. This will show the Setup Menu.

At any time when entering or changing values, the Esc (Escape)/Ack (acknowledge) key can be pressed, instead of the Enter key, which would save the change, and the value will revert to what it was before the change was attempted.

The top line shows the current login level. Five (5) indicates no privileges. Press the Down Arrow key to move the cursor to the Login line. Press enter, enter the code required using the numeric keys, then press Enter. Your login level will be shown. The login levels are shown in the administrator Menu. Administrator level is one (1), and allows access to all functions. There are additionally Levels 2, 3, and 4. After a login code has been entered, the privilege will last for the length of the Inactive/Auto Logout timer set in the Administrator Menu. This timer is reset every time a key is pressed after the Login level has been entered. Moving the cursor down using the Down Arrow key to the line "Event List", and pressing Enter will allow viewing the Event List. If the Event List is clear, the cursor will return to the \* on the first line. If the event list is not clear, the Right Arrow key will move through the Events. The Left Arrow key will move back to the last Event.

## Event List

The Events are labeled as a number out of the total number of events. Events are alarms and shutdowns. They are shown as when they became active with a date and time stamp, and then when they are acknowledged with a date and time stamp. To Exit the Event List, press the Home key.

Shown is a portion of a typical Event List. The first screen shows the event. The event is a shutdown which was reset. The second screen shows when the shutdown occurred. These are noted by the abbreviation "RST" for reset, and "ACT" for active. Up to 100 events are stored. These will be typically the shutdowns and when they are reset, so the last 50 shutdowns and their resets are saved.

```
RST Login(5) 5 of 34
07:06:55AM 26Jun2001
Shdn:Compressor
Hi Coolant Temp
```

# MC Series Standard Display Menus

## Administrator Menu

This is what the typical Administrator Menu looks like. The Administrator (Level [1]), and Level (2), Level (3), and Level(4) codes can be changed here. It is highly recommended not to change the Administrator code. The other codes have Murphy default values, similar to other Murphy controllers. For example, comparing to either Murphy EMS or S Series controllers, a typical Level (2) code is the same as the code for the M Numbers, a typical Level (3) code is the same as the code for the S Numbers, and a typical Level (4) code is the same as for the P Numbers.

*	C	h	a	n	g	e	P	a	s	s	w	r	d	s	*				
A	d	m	i	n	i	s	t	r	a	t	o	r	=	9	9	9	9	9	9
L	e	v	e	l		2	=	9	9	9	9	9	9	9	9	9	9	9	
L	e	v	e	l		3	=	9	9	9	9	9	9	9	9	9	9	9	
L	e	v	e	l		4	=	9	9	9	9	9	9	9	9	9	9	9	

The Inactive/Auto Logout Delay is the length of time after the last key press the Login Level will go back to Level (5), or no special privileges. This is usually left in the range of 600 seconds, or 10 minutes. If it is set too short, it can make changing parameters very difficult, because of the need to re-enter a login whenever the time times out, when the parameters have not been fully changed as desired.

The Event Display Delay is the length of time after a key press any active Event will be displayed over the current display. Whenever there is a current Event such as a shutdown, or alarm, that display will be shown until a key is pressed. After a key is pressed, and no more keys are pressed, the Event display will return after this length of time.

The Event Cycle Delay is the length of time each Event will stay on the

I	n	a	c	t	i	v	e	/	A	u	t	o	L	o	g	o	u	t
D	e	l	a	y									6	0	0	s	e	c
E	v	e	n	t	D	i	s	p	l	a	y	D	e	l	a	y		
													1	5	s	e	c	s

screen when there are multiple Events that are being displayed in turn.

The Cursor Off Delay is the amount of time after the last key press the cursor will turn itself off.

The Notify Message Delay is the length of time a message such as "Fn

E	v	e	n	t	C	y	c	l	e	D	e	l	a	y				
D	e	l	a	y									3	s	e	c	s	
C	u	r	s	o	r	O	f	f		D	e	l	a	y				
													6	0	s	e	c	s

Key Active" will show and allow the second key to be pressed.

The Modbus Slave Port is COM C. The Baud rate can be change here

N	o	t	i	f	y	M	e	s	s	a	g	e	D	e	l	a	y	
D	e	l	a	y									3	s	e	c	s	

from 9600 Baud to 19,200 Baud (19.2 Kbaud), to 38,400 Baud (38.4 Kbaud). To do this, the cursor must be on the line where the Baud rate is displayed. ENTER is pressed, then the Baud rate can be changed using the UP and DOWN keys. When the correct Baud rate is chosen which is compatible with the Modbus Master using COM C, ENTER is pressed again, and the Baud rate is selected.

M	o	d	b	u	s	S	l	a	v	e	P	o	r	t				
						B	a	u	d	R	a	t	e			9	6	0
						R	T	U	A	d	d	r	e	s				1

The Power supply Poll Rate and I/O Port Poll Rate can be changed in multiples of 55 milliseconds. The values here should not be changed without consultation with FWMurphy Millennium Controller experts. The values here work well for most all applications. It will only be a very unique application where these values are changed from their typical values.

P	w	r	S	u	p	p	l	y	P	o	l	l	R	a	t	e		
C	O	M	A			(	5	5	m	s		*	)			2		
I	/	O	P	o	r	t	P	o	l	l	R	a	t	e				
C	O	M	B			(	5	5	m	s		*	)			8		

The choice for Reset Controller can be used to reset the controller. This has the same effect as cycling the power, except the power does not have to be cycled. This is typically used to get to the Power-Up Setup to download a new application, or project, or do a Factory Test, Transfer a file to or from the DISKONCHIP, such as a trended data file, or any of the other functions allowed in the Power-Up Setup Menu.

**NOTE:** Caution should be used when resetting the controller. The user must realize that any control functions will cease, and if the equipment is running, it will be stopped by all outputs dropping out.

The choice for Debug Link Enable is used if it is desired to use ISaGRAF software to monitor program and controller operation. It slightly slows down I/O scan rates to service the ISaGRAF communications through the PC.

R	e	s	e	t	C	o	n	t	r	o	l	l	e	r					
																		N	
D	e	b	u	g	L	i	n	k	E	n	a	b	l	e					N
																		O	

## Clear Event List

With the proper level code, if the cursor is navigated to the Clear Event List line, and Enter is pressed, the display on that line will change to saying "Deleting...". When the dots get to the end of the line, the Events will have been cleared.

# MC Series Standard Display Menus

## Set Date & Time Menu

This is what the typical Set Date & Time Menu looks like.

With the proper level code entered, when the cursor is moved to the Set Date & Time Line, and Enter is pressed, the display will show:

*	S	e	t	D	a	t	e	&	T	i	m	e	*			
0	2	/	0	9	/	0	1					1	3	:	0	1
D	a	y				(	1	-	3	1	)	=	0	9		
M	o	n	t	h		(	1	-	1	2	)	=	0	2		

Y	e	a	r			(	0	0	-	9	9	)	=	0	1	
H	o	u	r	s		(	0	-	2	3	)	=	1	3		
M	i	n	s			(	0	-	5	9	)	=	0	1		
S	e	c	s			(	0	-	5	9	)	=	0	9		

Any or all of the displayed Date and Time data can be set by navigating to the appropriate line with the Up and Down arrow keys, pressing Enter, entering the corrected data using the numeric keypad, and pressing Enter, again.

## Force Menu

This is what the typical Force Menu looks like. With the proper level code entered, when the cursor is moved to the Force Menu, and Enter is pressed, the display will show:

*				F	o	r	c	e	M	e	n	u	*				
F	o	r	c	e	T	i	m	e	L	e	f	t	:	1	2	0	
E	n	a	b	l	e	F	o	r	c	e	:					N	o
D	I	G	I	T	A	L	O	U	T	P	U	T	S				

O	u	t	p	u	t	1	:	O	f	f							
O	u	t	p	u	t	2	:	O	f	f							

O	u	t	p	u	t	3	:	O	f	f							
O	u	t	p	u	t	4	:	O	f	f							
O	u	t	p	u	t	5	:	O	f	f							
O	u	t	p	u	t	6	:	O	f	f							

O	u	t	p	u	t	7	:	O	f	f							
O	u	t	p	u	t	8	:	O	f	f							
F	o	r	c	e	T	i	m	e	L	e	f	t	:	1	2	0	
A	N	A	L	O	G	O	U	T	P	U	T	S					

A	n	a	l	o	g	O	u	t	1	:	1	0	0	.	0	0	
S	P	A	N	=	6	0	0										
Z	E	R	O	=	1	0	0										
A	n	a	l	o	g	O	u	t	2	:	1	0	0	.	0		

S	P	A	N	=	9	5	0										
Z	E	R	O	=	1	0	0										
D	I	G	I	T	A	L	P	O	T								2
																	5

With the administrator login code, the outputs can be forced. First "Enable Force" must be set to "Yes". Next, the cursor can be moved to any line where "Off" can be changed to "On". The analog output values can be forced to any value. As long as keys are being pressed, the force time left will be reset to the maximum value. If no keys are pressed, the timer will time out and the forces will be removed.

# MC Series Troubleshooting Instructions

## If There Is No Display on the Controller

Check the power input to the power supply. It should be between 10 and 32 VDC. Make sure the wiring is per the instructions, and all grounds are properly connected. If the power to the power supply is within tolerance, check the power to the MCH display head. This can be done by removing the hood on the head end of the power supply cable. There are two pairs of wires in the power supply cable. The larger gage wires are the power, and with the head connected there should be 5.00 VDC +/- 0.25 VDC at the head end of the cable. If the 5 VDC is not present within tolerance, disconnect the head and measure the same voltage. The power supply should be able to supply 5.00 VDC +/- 0.25 VDC at up to 3 Amps load. If it cannot perform as explained, return it for repair. If the power is within specifications, return the head for repair.

## Checking the Digital Inputs

There are LED's for each of the inputs. The status of the inputs is also displayed on one of the standard displays of the Millennium controller head. **See Screen A, below.** If the input is not working, check the wiring per the instructions. Check to see if jumpers are used, or if external power is used. Use a meter to test the inputs connections for voltage within the published specifications for voltage and current.

## Checking the Digital Outputs

The relays have LED's to show their status. Both the relays and the SSR's (Solid State Relays) have their status shown in the standard displays of the MCH. **See Screen B, below.** Make sure the wiring is correct per the instructions. Use a meter to measure voltage and current. On the relays, with no wires connected, a continuity test, or Ohm meter can be used to verify the Common to Normally Open and Common to Normally Closed contacts. The outputs can be forced. (**See Page 25**).

## Checking the Analog Outputs

Use a meter to measure milliAmps. The analog outputs can be forced, zeroed and spanned **See Page 25**. Make sure the power supply voltage is correct for the analog output load. Make sure which model power supply is used. Some power supplies have no analog outputs, some have one, others have two.

## Checking the Speed Input

Measure AC volts and frequency with a meter. Compare to the published specifications.

Screen A

Inputs															
11111111															
6543210987654321															
000000000000XX00X0															

Screen B

Outputs															
87654321															
000XX00X															





## Modbus RTU I/O Expansion Modules

C267 (00004923) 8 Digital Inputs, 7 Analog Inputs, Power supply monitor, Discrete outputs

C277 (00007620) 18 Thermocouples/4-20 mA

C287 (00005945) 4 Analog Inputs, 4 Analog Outputs

## Accessories

### Cables and harnesses (for C267, C277 C287)

00005293	RJ45 2-foot cable assembly
00004925	RJ45 4-foot cable assembly
00005292	Terminating Resistor Module
00007621	RJ45 to DB9 cable assembly

### Cables and harnesses for C267 only

00007196	HARNESS,C267 10 WIRE MOLEX to C267TBIF
00007197	HARNESS,C267 18 WIRE MOLEX to C267TBIF
00007719	Interface Terminal board C267TBIF
00004924	Molex to raw wires harness, 2 ft. long 35267HRNSKIT

### Cables and harnesses for C287 only

00008544	C287 harness kit 35287HRNSKIT
----------	-------------------------------

## Configuration and Programming/Software

ISaGRAF 3.4 256 (WD16) – Ladder logic (IEC-61131-3) programming and monitoring software for up to 256 tag names

ISaGRAF 3.4L (WDL) – Ladder logic (IEC-61131-3) programming and monitoring software for unlimited number of tag names

MTools – Display, set point, and alarm screen configuration, initial and default value setting, Modbus register map creation and file transfer utilities.

## Options

MCCP Hold-up capacitor package (for 12 VDC cranking battery systems)

### Warranty

A limited warranty on materials and workmanship is given with this FW Murphy product. A copy of the warranty may be viewed or printed by going to [www.fwmurphy.com/support/warranty.htm](http://www.fwmurphy.com/support/warranty.htm)

## **RJ Mann & Associates Inc.**

*Engine Controls & Panels/Compressor Parts*

860 North 9th Avenue, Brighton, CO 80603

Ph: (303) 659-5139 Fax: (303) 659-5309

[www.rjmann.com](http://www.rjmann.com)



USA-800-9001-2000 FAX 78221  
UK-459-9001-2000 FAX 29422

**ISO 9001**  
REGISTERED