

Installation and Operation of the DF Series Hydrostatic Head Level Switches



Please read the following information before installing. A visual inspection of this product for damage during shipping is recommended before mounting. It is your responsibility to have a qualified person install this unit and make sure it conforms to NEC and local codes.

GENERAL INFORMATION

WARNING

BEFORE BEGINNING INSTALLATION OF THIS MURPHY PRODUCT

- ✓ Disconnect all electrical power to the machine.
- ✓ Make sure the machine cannot operate during installation.
- ✓ Follow all safety warnings of the machine manufacturer.
- ✓ Read and follow all installation instructions.



CAUTION: Certain dangers to human safety and to equipment may occur if some equipment is stopped without pre-warning. It is recommended that monitored functions be limited to alarm only or to alarm before shutdown.

Description

The DF series are diaphragm operated “hydrostatic head pressure” level switches. A pressure sensitive diaphragm operates a snap-switch that can be wired directly to electric pilot circuits to control pumps at predetermined levels. Typical application is to start and stop electric driven pump(s) to maintain tank levels. It is also applicable to engine driven pumps.

The Nitrile sensing diaphragm is impervious to most liquids and is sensitive enough to control levels with 1/4 in. (6 mm) repeatability. See model descriptions for limits of switch trip point adjustability. Materials include aluminum body, nylon bottom plate and a special alloy leaf snap-switch as standard.

This simple level switch is highly reliable and can be worked into most new or existing system without major modification or special tools.

DF755 and DF757 are suitable for atmospheric tanks in a non-hazardous location.

The SPDT snap-switch for the DF755 is preset for a 4 in. (102 mm) differential in liquid level, operating at approx. 6 inches (152 mm) rising, and resetting at approx. 2 inches (51 mm) falling level.

The DF757 trip point is adjustable over a 108 inches (2743 mm) differential.



Specifications

Snap-switch Ratings

SPDT (standard—all models)

- 5 A @ 125, 250, or 480 VAC
- 1/2 A @ 125 VDC, 1/4 A @ 250 VDC

Case/Lid: Aluminum (standard); all non-explosion proof models.

Bottom Plate: Glass-filled nylon.

Process Connection: 1 NPT (standard)

Maximum Pressure Rating: 25 psi (172 kPa) [1.72 Bar].

Conduit Connection (electrical): 1/2 NPT.

Warranty

A limited warranty on materials and workmanship is given with this FW Murphy product. A copy of the warranty may be viewed or printed by going to www.fwmurphy.com/support/warranty.htm

DIMENSIONS

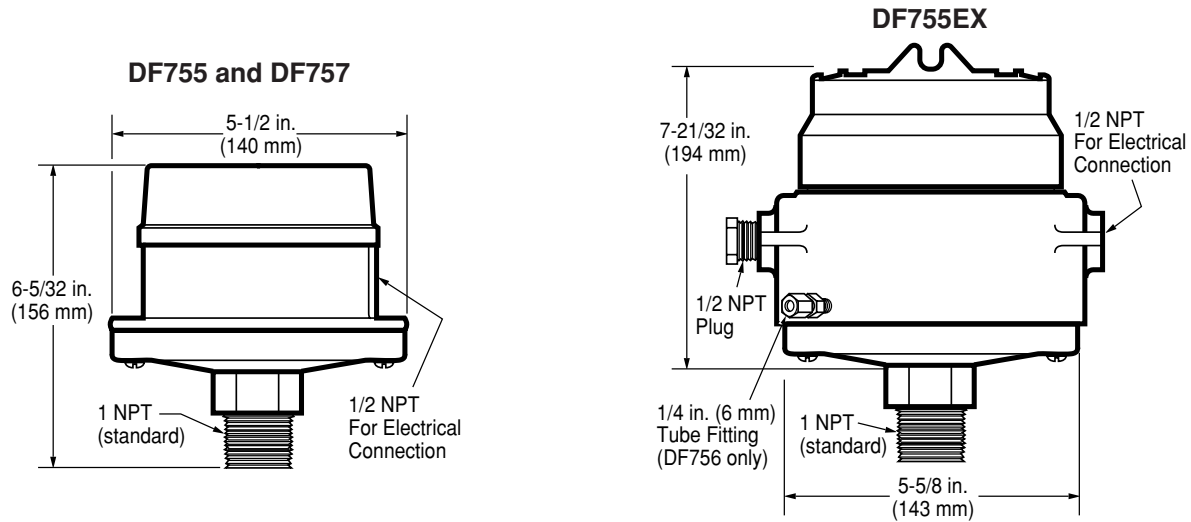

TYPICAL APPLICATIONS

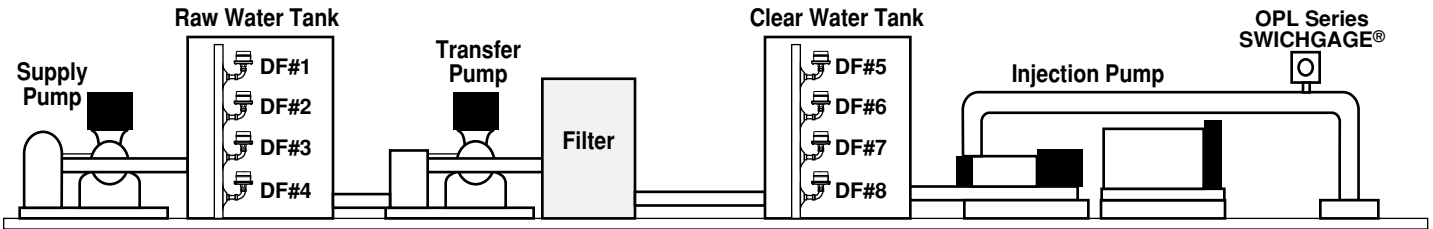

Typical Water Flood Control System

The diagram above displays eight DF Series switches installed on a Raw Water tank and a Clear Water tank. When raw water rises to predetermined level, **DF#1** stops the supply pump. As tank level falls below the predetermined level, **DF#2** starts the supply pump. If the tank level continues to fall, **DF#3** initiates shutdown of the supply pump. **DF#4** stops transfer pump before raw water tank is completely pumped out.

When clear water reaches the predetermined level, **DF#5** stops the

transfer pump. As tank level falls to predetermined low level, **DF#6** starts the transfer pump. If the tank level continues to fall due to the failure of the filters section, **DF#7** initiates shutdown of the transfer pump. (DF755 located at this level will also operate backwash equipment). **DF#8** stops injection pump before tank pumps completely out.

An OPL Series pressure SWICHGAGE® stops injection pump when pressure reaches predetermined high or low pressure.

Tank with Low Pressure Gas Blanket (DF755EX)

The DF755EX (below) is shown installed on a crude oil tank where a low pressure gas blanket is used to prevent evaporation loss. It is mounted directly to the side of the tank or on riser pipe 4 to 7 in. (102 to 178 mm) below level to be controlled. Pump automatically stops or starts when liquid reaches predetermined high or low level.

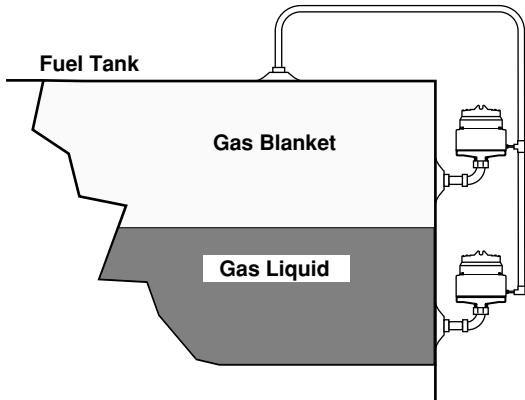

Typical Tank Mounting Methods (DF755)

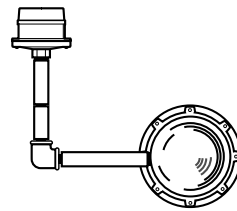

Bull Plug Installation

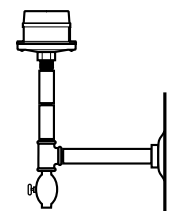

Tank Wall Mounting With Drain Cock

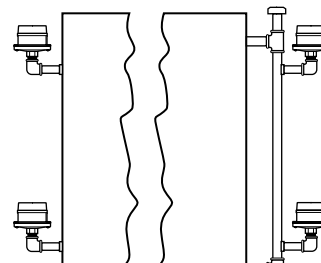

Directly On Tank

Riser Pipe Method

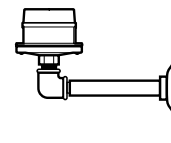

Tank Wall Mounting

BASIC OPERATION

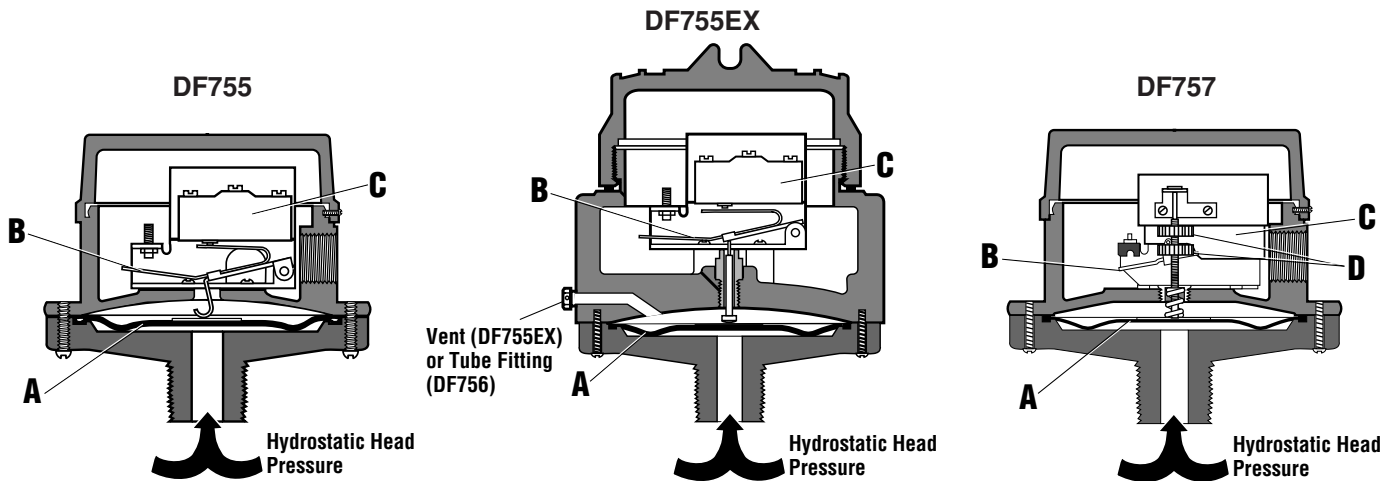

As the liquid level rises, hydrostatic head pressure is applied to the diaphragm **A**. The diaphragm is forced upward forcing the actuator arm **B** to activate the snap-switch **C**.

Models DF755 and DF755EX are factory set and operate at approximately 2 in. (51 mm) and 6 in. (152 mm) rising above the level at which the diaphragm is mounted. The switch resets back to normal condition at approx. 2 inches (51 mm) falling level. The trip point(s) for Model DF757 are adjustable between 2 in. (51 mm) and 110 in. (2794 mm) for high and low (make/break) operation by knobs, **D**.

For sealed tanks, model DF755EX can be fitted with a tube fitting to balance the top of the diaphragm chamber to a tank gas blanket (see Typical Applications). The DF755EX is supplied with an atmospheric vent fitting.

Setpoint Adjustment (DF757)

1. Locate threaded adjustment shaft and adjustment knobs (see drawing above).
2. To increase low level setpoint, rotate lower knob counterclockwise.

NOTE: If adjustment shaft turns when rotating adjustment knobs, grasp the adjustment shaft with a pair of needle nose pliers—then rotate knob.

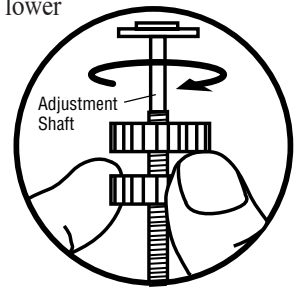

USING THE DF755 WITH MAC1 VOLUME CELL ACCESSORY

The **MAC1 Volume Air Cell** when attached to the DF755 can monitor water levels on a sump. Activate alarms or start a pump directly. The MAC1 Volume Air Cell is non-corrosive and provides 1/4-20 stainless steel mounting studs.

The **MACT1 Tubing Kit** provides 4 ft. (1.2 m) flexible, non-corrosive 1/4 in. (6 mm) tubing (cut to fit). The kit includes necessary fittings to attach tubing.

Both the MAC1 air cell and MACT1 tubing kit are available from Murphy.

Volume Cell Operation

As liquid rises around the volume cell, it compresses air inside the cell and forces it up in the sensor line. As air pressure increases due to the water level continuing to rise, sufficient pressure will be applied to activate the internal snap-switch, which in turn starts the pump. As the liquid level is pumped down, pressure decreases and the above procedure is reversed. The pump is stopped and held in a standby condition. An air purge may be required in the sensor line. Consult factory.

Choosing a Volume Cell

The volume cell should be constructed of material which will be unaffected by the liquid being measured. For proper “pressure-to-level” ratio, the minimum dimensions of the volume cell should be 6 in. (152 mm) inside diameter and 3 in. (76 mm) inside depth. The sensor line can be of any diameter or material either flexible, or solid, as long as it is of sufficient length to reach from the volume cell to the desired loca-

tion for the DF755. All fittings and connections should be air-tight to avoid loss of “charge”. Tube lengths longer than 4 ft. (1.2 m) should have provision for periodic air purging.

Installation of the Volume Cell

Install the volume cell according to the level you wish the pump to start and stop. Secured the volume cell with a substantial bracket which will not allow the cell to be “floated” or tilted when the water level rises. The DF755 should be installed well above the highest water level and in a position that will allow access for adjustment or repair.

NOTE: Periodically operate pump manually until water level reaches a point approximately 1/2 in. (13 mm) below bottom of the volume cell. This will automatically re-charge the unit and compensate for normal absorption of air into water. Small electric air pumps are available to automatically charge system at all times.

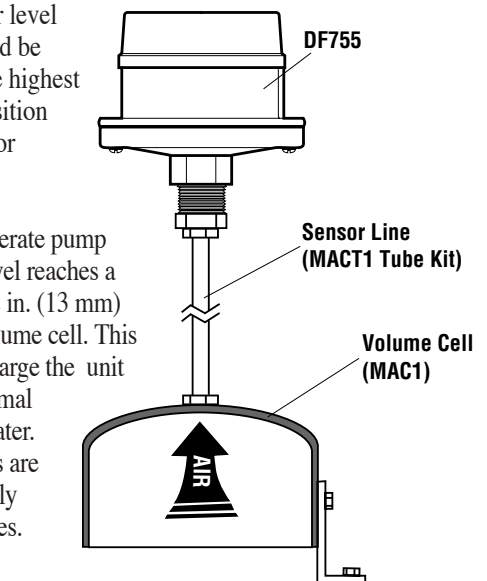

TYPICAL WIRING

Starts at Low Level, Stops at High

Start motor when predetermined low level is reached and stop when high level is reached. Keeps tank level within selected limits. Motor starter equipped with H.O.A.

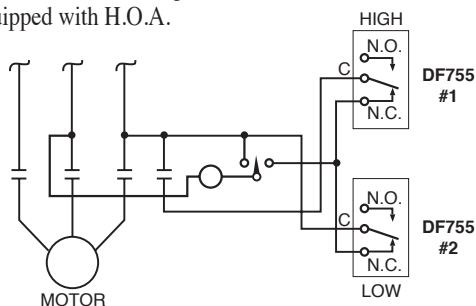

Starts at High Level, Stops at Low

Start motor when predetermined high level is reached and stop when low level is reached. Motor starter equipped with H.O.A.

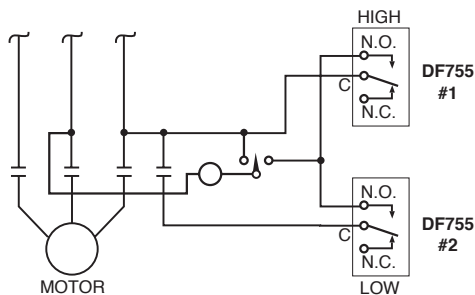

Single Magneto Shutdown

Wiring of magneto to N.O. switch terminal will shut down engine at predetermined high level, shown below. Wire to N.C. terminal to shutdown on low level.

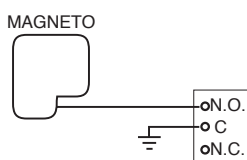

Dual Magneto Shutdown

Shutdown dual magneto engines using Murphy MS2120 Magnetic Switch. Diagram below shows hookup for low level shutdown. Wiring changes and mounting locations are necessary for high level shutdowns.

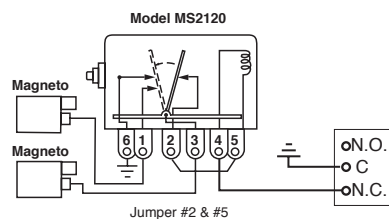

SERVICE PARTS

DF755

Description

Cover (aluminum)	15050081
Case (aluminum)	15050082
Cover Screws (3), #6-32 x 5/16 round head	80040607
SPDT snap-switch and movement assembly/repair kit (5 amp)	15000122
Screws (3) for switch assembly to case, #6-32 x 1/4 round head	80040605
Diaphragm repair kit	15000123
Bottom Plate (1 NPT connection)	15050083
Bracket and movement repair kit	15000313
SPDT snap-switch and insulator repair kit (5 amp)	15000121

Part Number

DF757

Description

Cover (aluminum)	15050081
Case (aluminum)	15050594
Cover Screw (3), #6-32 x 5/16 round head	80040607
SPDT snap-switch and bracket assembly/repair kit (5 amp)	15000174
Screws (2) for switch bracket and assembly to case (#6-32 x 1/4 round head)	80040605
Spring and piston assembly/repair kit	15000190
Diaphragm repair kit	15000123
Bottom Plate (1 NPT connection)	15050083
SPDT snap-switch and insulator repair kit (5 amp)	15000230

DF755EX

Cover (aluminum)	15050154
Case (aluminum)	15050155
Gasket	15050305
SPDT snap-switch and movement assembly/repair kit (5 amp)	15000118
Screws (2) for switch assembly to case, #6-32 x 1/4 round head	80040605
Actuator assembly/repair kit	15000119
Diaphragm repair kit	15000123
Bottom Plate (1 NPT connection)	15050083
Screw (1), #8-32 x 1/4 round head	80040814
Terminal cup washer	00000827
Plug 1/8 plastic pipe hex (DF755EX)	86060203
Connector, 1/4 tube x 1/8 pipe male (DF756)	85030402
Plug 1/2 NPT hex (brass)	86060801
SPDT snap-switch and insulator repair kit (5 amp)	15000117

RJ Mann & Associates Inc.

Engine Controls & Panels/Compressor Parts

860 North 9th Avenue, Brighton, CO 80603
 Ph: (303) 659-5139 Fax: (303) 659-5309
www.rjmann.com

