

Level Maintainer – LM300 Series



LM301-EX

Patent 5493086

Features

- Maintains proper lube level
- Shutdown on low level, or high and low level
- Low level alarm before shutdown
- Manual float switch test
- High visibility “Frog Eye” lens
- Optional pipe or universal mounting brackets
- Optional inlet orifices for low to high pressure applications
- Explosion-proof models available



*



* Pending

† Products covered by this bulletin comply with EMC Council directive 89/336/EEC regarding electromagnetic compatibility except as noted.

Description

The LM300 Series Level Maintainer automatically adds oil to the crankcase as needed to keep the lube level normal. Most models have built-in switches that will alarm and/or shutdown the equipment if the makeup supply is depleted and engine oil level falls or if overfill conditions exist. LM300 series explosion-proof models are CSA certified† for Class I, Division 1 Hazardous areas.

Applications

- Engines
- Compressors
- Pumps
- Coolers

Base Models‡

LM300: Level Maintainer only (no switches).

LM301: Low switch contacts for low level shutdown or alarm. Four wires, SPDT.

LM302: Two switches for low and high level shutdown or alarm. Four wires, DPST, wired N.O. in normal operating ranges.

LM303: Two switches for low and high level shutdown or alarm. Four wires, DPST, wired N.C. in normal operating ranges.

LM304: Two switches. Alarm before shutdown on low level and shutdown on low-low level. Four wires, DPST, wired N.O. in normal operating ranges.

LM305: Two switches. Alarm before shutdown on low level and shutdown on low-low level. Four wires, DPST, wired N.C. in normal operating ranges.

Specifications

Case/Cover: Die cast aluminum.

Switch Housing: Aluminum.

Approval Rating: LM301 thru LM305: CSA certified† for non hazardous locations. Enclosure Type 4 certified.

LM301-EX thru LM305-EX: CSA certified† for Class I, Groups C and D; Class II, Groups F and G hazardous locations. Enclosure Type 4 certified.

Float: Rigid polyurethane foam. Polyurethane coated.

Max. Ambient Temperature: 250°F (121°C)

Oil Inlet Connection: Top entry 1/2-14 NPT with built-in filter screen (removable for cleaning).

Inlet Orifices: 1/4 in. (6 mm) standard. 1/8 in. (3 mm) available.

Wire (switch models): 18 AWG x 13 in. (1.0 mm² x 330 mm).

Max. Inlet Pressure (MIP): 30 psi (207 kPa) [2.07 bar] with 1/8 in. (3 mm) orifice. 15 ft oil (4.6 m oil) with 1/4 in. (6 mm) orifice.

Max. Differential: 2 in. (51 mm) between running and stationary oil level.

Max. Case Pressure (MCP): 15 psi (103 kPa) [1.03 bar].

Orifice Seal†: Buna-N Thumb-Valve™

Switch Contact: Silver, SPDT snap acting, rated at 10 A @ 125, 250 VAC; 10 A @ 30 VDC. (1 only for low level; 2 only for high and low; or 2 only for low level with alarm before shutdown)

Flow Rate Test: Using SAE 30 @ 32°F (0°C).

Orifice Diameter	Pressure	Flow Rates
1/4 in. (6 mm)	4 ft. oil – 15 ft. oil (1.2 m oil – 4.6 m oil)	4.7 GPH - 31.0 GPH (17.8 LPH - 117.3 LPH)
1/8 in. (3 mm)	10 psig – 30 psig (68.9 kPa – 207 kPa) [.69 – 2.07 bar]	16.9 GPH - 32.1 GPH (63.7 LPH - 121.5 LPH)

* Standard

■ NOTE: Friction losses due to piping NOT considered.

Outlet Connection: 3/4-14 NPT left side, right side, and bottom.

Crankcase Balance Vent Fitting: 1/2-14 NPT.

Mounting: Accepts Murphy pipe mounting bracket or universal mounting bracket.

Lens: Clear “Frog Eye” non-staining, high impact, high temperature nylon; UV and heat stabilized.

Dial: High visibility white background with green and white “index” lines for normal level indication.

Test Knob: Rotate to test switch operation. Turn clockwise for low level test and turn counterclockwise for high level test.

† CSA certified with switch contacts rated at 10 A at 250 V AC (standard).

‡ Specify “EX” for explosion-proof enclosure. All models except LM300 are available in an explosion-proof enclosure.

Dimensions

The dimensions below are for the optional "EX" model enclosure. The standard model enclosure dimensions are the same except the height and width which are: 7 in. (178 mm) H, 7-7/8 in. (200 mm) W.

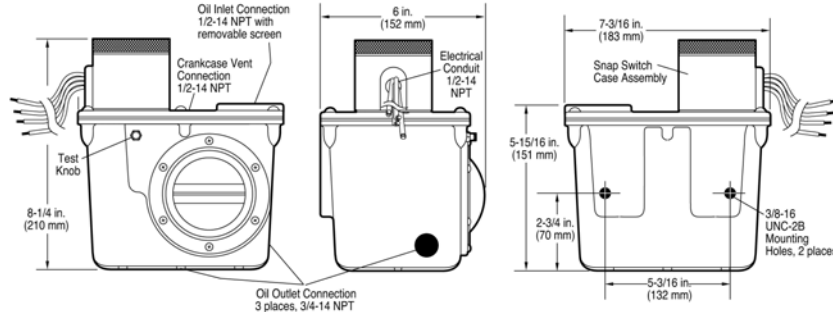

Mounting Brackets with Hardware

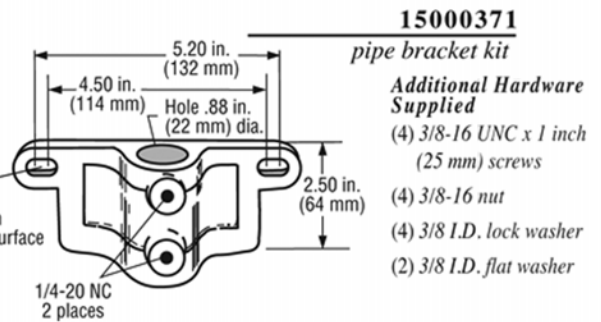
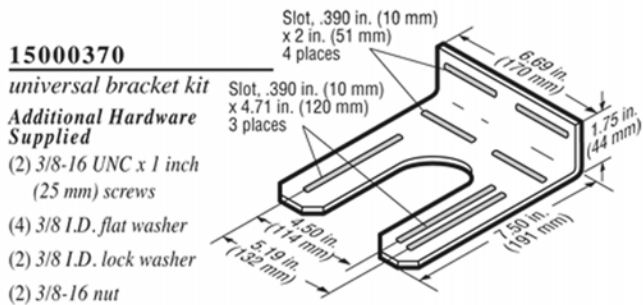

How to Order

Build a complete model number using the following chart. See example. See reverse page for standard and optional specifications.

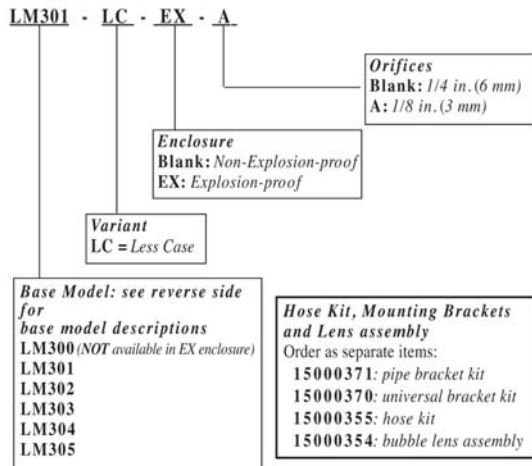

Shipping Information

Shipping Weights:

- LM300 Series non-"EX" models: 6 lbs. 6 ozs. (2.89 kg)
- LM300 Series "EX" models: 6 lbs. 12 ozs. (3.06 kg)

Shipping Dimensions (all LM300 Series models):

- 10-5/8 x 8-7/8 x 6-3/4 in. (270 x 225 x 171 mm)

Optional Hose Kit: 15000355

Quantity	Description
1	1/2 in. (13 mm) I.D. x 3 ft. (914 mm) long hose
1	1 in. (25 mm) I.D. x 3 ft. (914 mm) long hose
2	1/2 in. (13 mm) worm gear clamp
2	1 in. (25 mm) worm gear clamp
2	1/2 NPT x 1/2 in. (13 mm) barbed fitting
2	3/4 NPT x 1 in. (25 mm) barbed fitting

RJ Mann & Associates Inc.

Engine Controls & Panels/Compressor Parts

860 North 9th Avenue, Brighton, CO 80603

Ph: (303) 659-5139 Fax: (303) 659-5309

www.rjmann.com

Warranty - A limited warranty on materials and workmanship is given with this FW Murphy product. A copy of the warranty may be viewed or printed by going to <http://www.fwmurphy.com/warranty>