

Installation Instructions for Pressure and Vacuum 2 and 2-1/2 in. (51 and 64 mm) Dial Murphygage® and Swichgagage® Instruments. 20, 25, A20, A25 Series

00-02-0162
Revised 02-06
Section 05



Please read the following instructions before installing. A visual inspection of this product for damage during shipping is recommended.

GENERAL INFORMATION

WARNING

BEFORE BEGINNING INSTALLATION OF THIS MURPHY PRODUCT

- ✓ Disconnect all electrical power to the machine.
- ✓ Make sure the machine cannot operate during installation.
- ✓ Follow all safety warnings of the machine manufacturer.
- ✓ Read and follow all installation instructions.

Description

The 2 and 2-1/2 in. (51 and 64 mm) dial size Murphygage and Swichgagage instruments are diaphragm-actuated, pressure or vacuum gages with a 1/8-27 NPTM pressure port connection (2 pressure ports for differential pressure models).

Models with face-adjustable contact(s) are rated for 2 A @ 30 V (pilot duty). If the gage case is steel (20P, 25P, 20DP, 25DP etc.) the ground path for the contact circuit is through the case. Therefore, the case must be installed in the ground plane of the electrical power supply.

If the case is polycarbonate (A20P, A20DP, A25P, A25DP etc.) the ground path is isolated and is made through the "C" or "P" terminals on the back of the gage case ("C" for A20 models; "P" for A25 models).

Models 20PE, 25PE, A20PE, A25PE etc. have a snap-acting switch instead of the face adjustable pointer type contact. Electrical rating is 3 A @ 30 VDC, 4 A @ 125 VAC. Reset differential for the switch is approximately 10% of the scale.

NOTE: Select a scale so your normal operating pressure is in the upper middle of the scale.



CAUTION: Certain dangers to human safety and to equipment may occur if some equipment is stopped without pre-warning. It is recommended that monitored functions be limited to alarm-only or to alarm before shutdown.

Alarm Before Shutdown Models

The 20PABS, A20PABS, 25PABS and A25PABS feature a front limit contact for equipment shut-down and an internal SPDT snap switch for Alarm Before Shut-Down. When the low side (preset point) of the snap switch trips, the N.C. terminal completes a circuit to activate an alarm. A continued decrease in pressure will complete the shutdown circuit. An increase in pressure of approximately 10% of scale is necessary before the snap-switch (alarm) will reset and open the circuit.

NOTE: Face contact shut-down limit setting and snap switch low point are factory-set; specify when ordering if setting is other than standard.

Typical Tattletale® Magnetic Switch

Murphy manufactures several, patented Magnetic Switches for protection of the pilot duty Swichgagage contacts and to ensure positive shut-down of equipment. There are magnetic switches for CD ignition, Magneto, Battery systems and electric motor driven equipment. Tattletale annunciators show the cause of shut-down. The first one to trip will lockout all other Tattletale annunciators. Be sure the type of magnetic switch or Tattletale annunciator matches the power source used to trip it.

NOTE: At equipment start-up (for models not having a built-in time delay) the reset button must be held in until normal operation occurs, or an external time delay may be used. Instructions are packed with each Magnetic Switch or Tattletale annunciator.



Products covered by this literature comply with EMC Council directive 89/336/EEC regarding electromagnetic compatibility except as noted.

Typical Mounting Dimensions

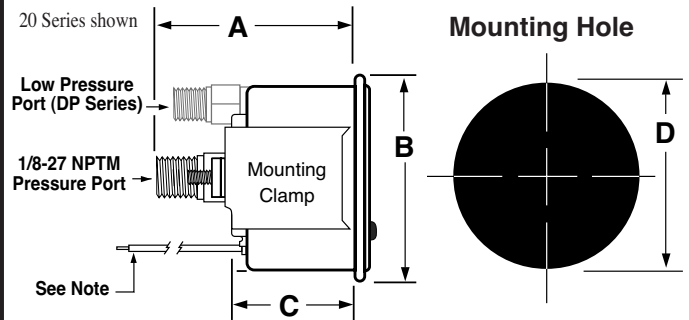

	20 Series	A20 Series	25 Series	A25 Series
A	2-7/32 (56)	2-9/16 (65)	2-1/8 (54)	1-51/64 (46)
B	2-15/64 (57)	2-1/4 (57)	3-1/8 (79)	2-29/32 (74)
C	1-5/16 (33)	1-1/4 (32)	1-3/8 (35)	1-27/64 (36)
D	2-1/16 (53)	2-1/16 (53)	2-11/16 (68)	2-11/16 (68)

NOTES: 20/25 Series: 18 AWG pigtails. A20/A25 series: #4/#6 screws. The dimensions above are in inches and (millimeters).

Panel Mounting

All models can be installed in a panel from 0.032 to 0.250 in. (1 to 6 mm) thick. Remove the mounting bracket and insert the gage from the front side of the panel. Replace bracket and secure it. Do **NOT** overtighten. (See Figure 2).

Connecting the Pressure Port

1. Pressure tubing is generally not provided. Use of good quality flexible pressure tubing/hose and fittings is strongly suggested. Use at least 3/16 in. (5 mm) I.D. tubing. If using copper or rigid tubing, install at least 12 in. (305 mm) flexible hose from the gage to the rigid tubing. This prevents damaging vibration from reaching the gage. For most models a pulsation orifice, within the pressure port, is provided and it is removable for cleaning (Figure 2).

2. Connect tubing to the 1/8-27 NPTM port. Use of non-hardening thread sealing compound is recommended although thread is "dry seal".

IMPORTANT: Make sure **NOT** to foul pressure orifices with sealant. **NEVER** exceed maximum pressure rating for the gage range; see chart on p-2.

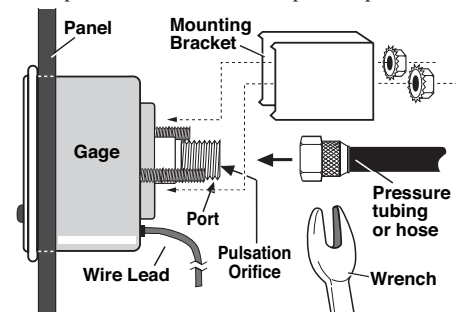

Figure 2

IMPORTANT: Swichgagage instruments, magnetic switches and shutdown or alarm devices, properly used, are effective tools in any preventive maintenance program. For optimum performance, check these tools periodically: look for frozen pointers, kinked/worn tubing, broken wiring or loose connections; operate the contacts and watch for expected results. Replace damaged/worn parts; clean/repair as necessary. Check for correct/complete wiring, unbroken insulation and no accidental grounds. Do not run shut-down wires with ignition wiring. Check all tubing and connections for leaks. Mount magnetic switches and valves upright, to prevent moisture collection.

Pressure Ranges and Factory Settings

Ranges Available		Maximum Pressure	Std. Settings*		Hi Settings**		20/25PABS Settings				Start-up Lockout Settings					
psi	Bar		psi	Bar	psi	Bar	Low		Alarm†		Contact		Lockout		Release (max.)	
							psi	Bar	psi	Bar	psi	Bar	psi	Bar	psi	Bar
0-15 (103)	1.0	30 psi (21 MPa)	3 (21)	0.2	12 (83)	0.8	3 (21)	0.2	6 (41)	0.3	3 (21)	0.2	4 (28)	0.3	6 (41)	0.4
0-30 (207)	2.0	60 psi (21 MPa)	7 (48)	0.4	24 (165)	1.6	7 (48)	0.4	10 (69)	0.6	4 (28)	0.4	7 (48)	0.5	10 (69)	0.7
0-50 (345)	3.5	100 psi (21 MPa)	10 (69)	0.8	40 (276)	2.8	10 (69)	0.8	13 (90)	1.0	10 (69)	0.5	13 (90)	1.0	20 (138)	1.4
0-75 (517)	5.0	150 psi (21 MPa)	15 (103)	1.0	60 (414)	4.0	15 (103)	1.0	18 (124)	1.5	10 (69)	0.7	15 (103)	1.0	23 (159)	1.6
0-100 (690)	7.0	200 psi (21 MPa)	20 (138)	1.5	80 (552)	5.5	20 (138)	1.0	23 (159)	1.5	20 (138)	1.0	25 (173)	2.0	35 (241)	2.4
0-150 (1.0 MPa)	10	300 psi (3.4 MPa)	30 (207)	2.0	120 (827)	8.0	30 (207)	1.5	33 (228)	2.0	20 (138)	1.5	30 (207)	2.0	45 (310)	3.1
0-200 (1.4 MPa)	14	400 psi (3.4 MPa)	50 (345)	3.0	150 (1 MPa)	10	50 (345)	3.0	53 (365)	4.0	40 (276)	3.0	50 (345)	3.5	70 (482)	4.8
0-300 (2.1 MPa)	20	500 psi (3.4 MPa)	75 (517)	5.0	225 (1.6 MPa)	15	75 (517)	5.0	78 (538)	5.0	50 (345)	3.5	75 (517)	5.0	105 (724)	7.2
0-400 (2.8 MPa)	28	500 psi (3.4 MPa)	150 (1MPa)	7.0	300 (2.1 MPa)	20	75 (517)	5.0	150 (1MPa)	10	100 (690)	6.0	—	7.0	150 (1MPa)	10

Values in () are mathematical conversions from psi to kPa/MPa—they do not reflect second scale range. U.S.A. standard scale is psi/kPa; U.K. standard scale is psi/bar. Consult factory for other scales.

* Standard setting for 20P/25P and 20PE/25PE models.

** Low settings for Hi/Lo option same as standard settings. Hi/Lo option available for 20P/25P models only.

† SPDT Snap-switch is the alarm switch.

Connecting Vacuum Models

The vacuum instruments measure intake manifold vacuum and gives an indication of the load applied to the engine.

1. Mount the gage in a suitable location so that the face is visible and easily accessible.

CAUTION: Make SURE NOT TO FOUL the pressure orifices with pipe dope or dirt or the SWICHGAGE instrument will not operate.

2. Connect suitable tubing to the 1/8-27 NPT port of the gage and to an open port in the intake manifold. Mounting kit V5179 is suggested and includes tubing and necessary fittings. The manifold fitting is 1/4 NPT. **Figure 3** shows a typical mounting using V5179 kit. A Murphy PD2160 is also recommended.

3. Be sure connections are tight—gage will not operate properly if line leaks.

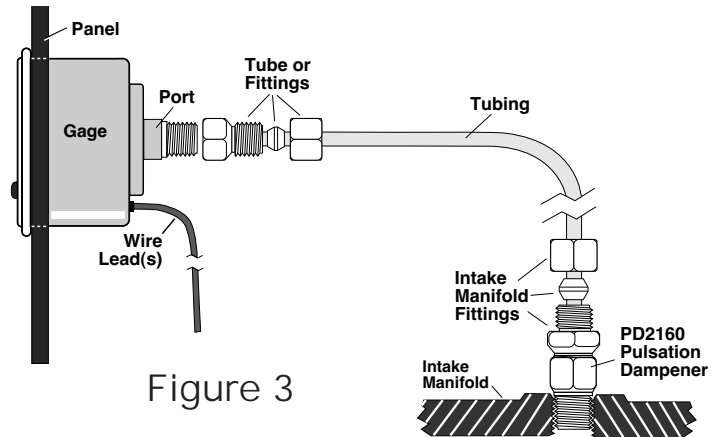

Figure 3

Connecting Differential Pressure Models

Differential pressure models are typically applied to indicate restriction in oil/fuel filters. The “High” pressure port (center mounted) is piped to the Inlet side of the filter. The “Low” pressure port (top center mounted) is piped to the Outlet side of the filter.

CAUTION: Make SURE NOT TO FOUL the pressure orifices with pipe dope or dirt or the SWICHGAGE® instrument will not operate.

1. To connect the high pressure tubing use at least 3/16 in. (5 mm) I.D. flexible pressure tubing/hose and fittings. If using copper or rigid tubing, install at least 12 in. (305 mm) flexible hose from the gage to the rigid tubing (to prevent damaging vibration to the gage, see **Figure 2**).

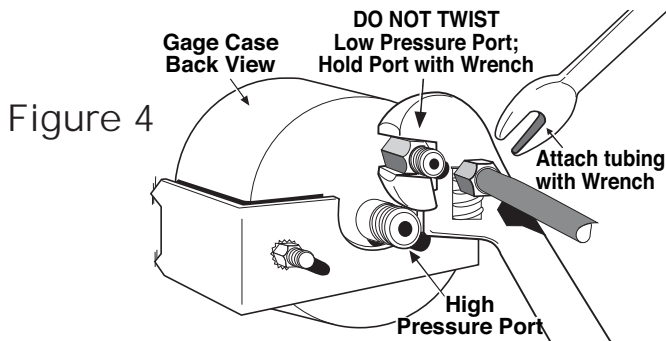

Figure 4

2. You **MUST** use a second wrench on the **Low Pressure** port when tightening tube fittings. (**Figure 4**). Notice that a wrench is used for holding the low pressure port while a second wrench will tighten the pressure tubing/hose fitting onto the port.

WARNING: Failure to use a second wrench on the low pressure port when tightening tube fittings may result in damage to the internal mechanisms.

IMPORTANT: NEVER exceed maximum static pressure or differential pressure ratings for your gage range; stated in chart below.

Ranges* Available	Max. Static Pressure	Max. Differential Pressure	Contact Setting
0-15 (0-103) [0-1.0]	200 (1.4) [14]	30 (207) [2.0]	10 (69) [0.8]
0-30 (0-207) [0-2.0]	300 (2.1) [20]	60 (414) [4.0]	20 (138) [1.0]
0-50 (0-345) [0-3.5]	300 (2.1) [20]	100 (690) [7.0]	30 (207) [2.0]
0-75 (0-517) [0-5.0]	300 (2.1) [20]	150 (1.0) [10]	50 (345) [3.5]
0-100 (0-690) [0-7.0]	300 (2.1) [20]	200 (1.4) [14]	60 (414) [4.0]

*Values are shown in psi, (kPa/MPa) and [bar]. Values in kPa/MPa and bar are mathematical conversions from psi—they do not reflect actual second scale range.

Setting the Swichgage instrument contacts



IMPORTANT: If the Swichgage has a lockout push button on the face, a contact setting higher than the factory setting will make the lockout device inoperative.

For 20PE, 25PE, 25DPE, A20PE, A25PE and A25DPE models the switch trip point **CANNOT** be set at either the lowest or the highest extremes of the scale. Trip point **MUST** allow for the switch reset differential. For adjustable switch versions, the switch point is adjustable **ONLY** over the lower half of the scale.

1. All contacts are set using a 1/16 in. hex wrench (Figure 5).
2. Some models such as A20PE, A25PE, etc. may not have field adjustment. Consult the factory if in doubt. For adjustable models, 1/4 turn clockwise lowers switch operating point approximately 7% of scale.
3. Observe the "normal operating" pressure or vacuum readings. Set the contact slightly **below** minimum reading observed or slightly **above** minimum pressure recommended by equipment manufacturer. For differential pressure models set the contact slightly **below** the desired maximum differential pressure.

Testing the Contacts

1. With equipment running; use a 1/16 in. hex wrench to rotate contact until it touches the pointer. **Do NOT force contact against the gage pointer.** Equipment should shut down and/or alarm should operate. *Reset the contact* (See Figure 5).
2. **VERY IMPORTANT** Each time you start the machine, observe that the SWICHGAGE® is indicating pressure or vacuum. Visual inspection and regular testing should be normal procedure to ensure proper operation and to achieve maximum results from your Swichgage instrument.

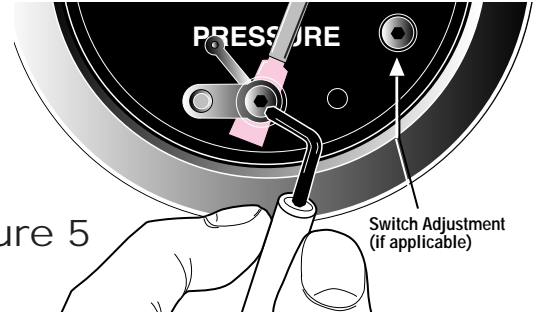

Figure 5

Wiring Installation



WARNING: DISCONNECT ALL ELECTRICAL POWER BEFORE BEGINNING THE WIRING INSTALLATION. FOR BATTERY IGNITION SYSTEMS, DISCONNECT THE BATTERY GROUND STRAP. FACE ADJUSTED POINTER TYPE CONTACTS ARE PILOT DUTY. DO NOT EXCEED CONTACT RATINGS ON ANY SWICHGAGE® MODEL.

20 and 25 Series models wire leads are 18 AWG or 20 AWG, 12 in. (305 mm) long. A20 and A25 Series models have number 4 or number 6 screw terminals.

When installing the Swichgage instrument on an ungrounded panel, you **MUST** provide a ground wire from the Swichgage instrument to a common ground. Install **ONLY** in a 12 or 24 V system. Warning lights or audible signal must be of the same voltage as the battery. Current draw should never exceed Swichgage contact ratings.

CAUTION: Ordinary incandescent lights are damaging to Swichgage contacts. We recommend using our direct connected alarms TL-7 flashing lamp and/or SAH mini-siren.

The pictorial below shows typical wirings for each base model. Look for specific typical wiring diagram with your base model number and wire accordingly.

The pointer is shown in the **Shelf Position**. Face adjusted pointer type contacts are rated pilot duty 2 A @ 30 VAC/DC. Snap-switch contacts are rated 3 A @ 30 VDC; 4 A @ 125 VAC.

CAUTION: On some models pointer contact and ABS switch share the same "Common". Voltage source must be the same. Maximum voltage is 30 V. Consult factory for applications with 120 VAC systems.

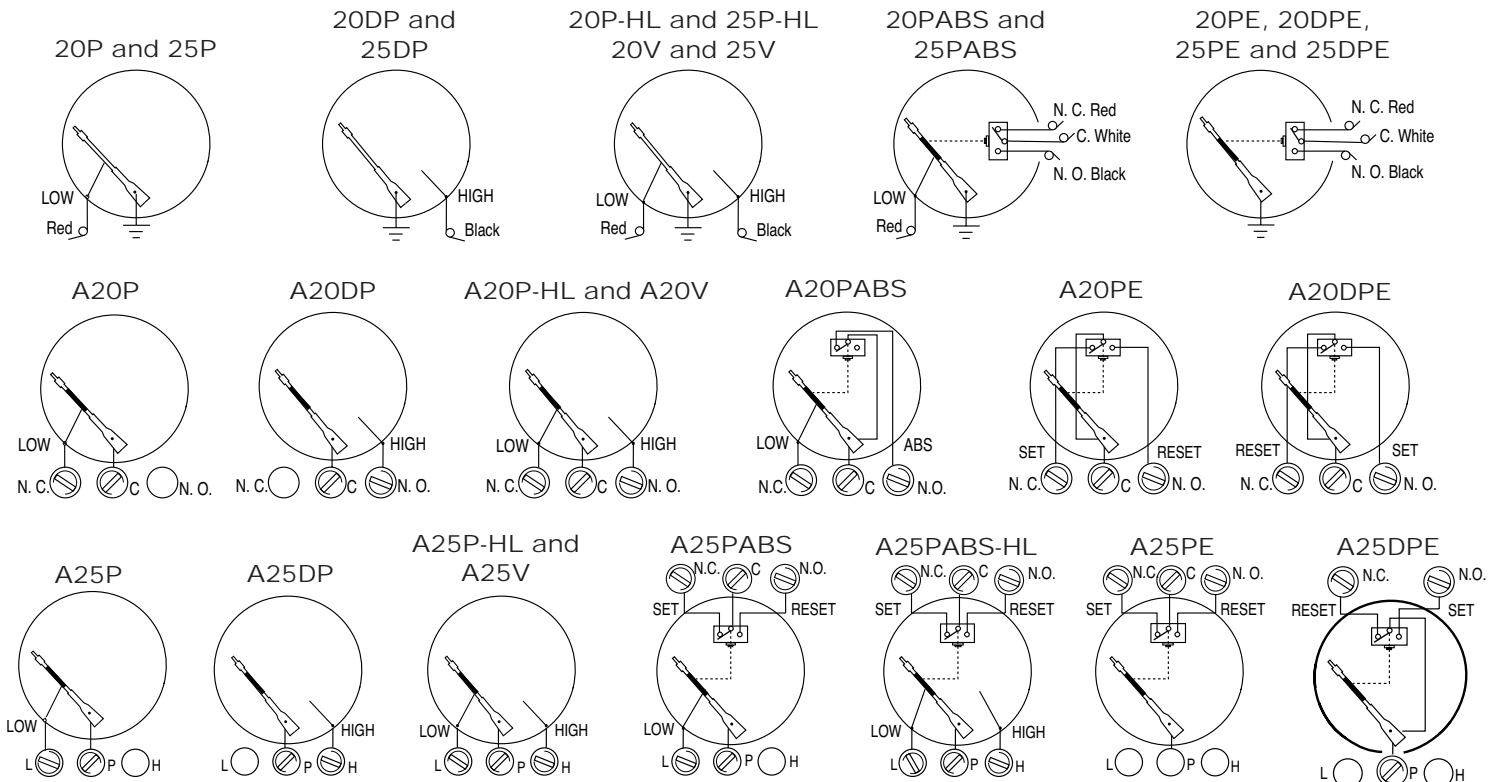

Installing The Magnetic Switch



WARNING: DISCONNECT THE BATTERY OR POWER SOURCE BEFORE BEGINNING THE INSTALLATION. SEE SPECIFIC WIRING INSTRUCTIONS PACKED WITH EACH MAGNETIC SWITCH OR TATTLETALE ANNUNCIATOR.

1. Mount with electrical lugs down. Drill mounting holes in panel.
2. Clean away burrs and filings. Position the magnetic switch in the panel, making sure the pilot stud is in place.
3. Add decal, then washer, then nut and tighten.

NOTE: Murphy components are easily wired and maintained. Use good quality wire and terminals. The type of magnetic switch differs for various applications. See typical wirings below. Wiring and instructions are packed with each magnetic switch.

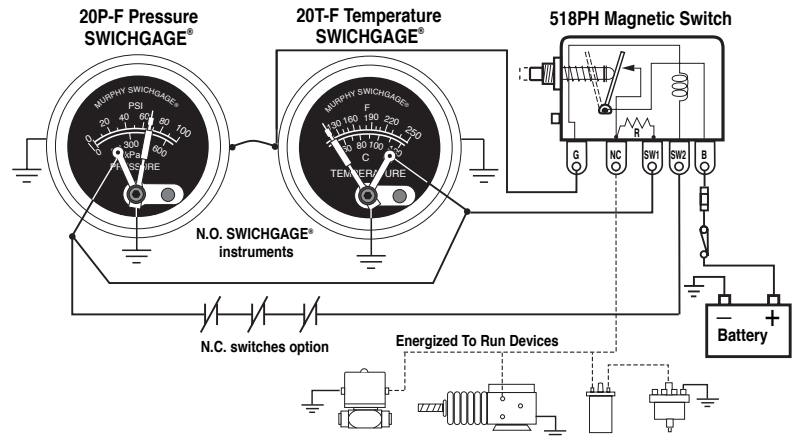
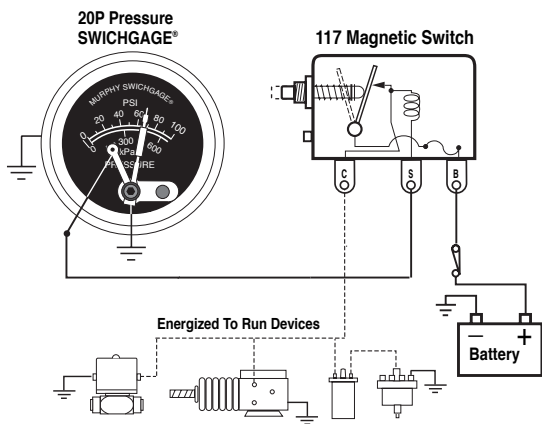

Troubleshooting

DO THIS FIRST: Look for broken wiring, frozen pointer, dirty contacts (will not make), burnt pointer or contact. Verify that all wiring is intact and connections are tight. Verify that Swichgauge has not been damaged (hit or dropped). Verify that there is pressure/vacuum supplied to the gage. Verify that the Swichgauge is operative (it reads). Verify that the alarm or shutdown device is fully operable; and check other components such as spark plugs, ignition, fuel pump and filter, etc. Reset magnetic switch and verify that it stays latched.

SYMPTOM	CAUSE	TEST/REMEDY
Engine will not start.	<ol style="list-style-type: none"> 1. Short or open circuit, be sure the magnetic switch latches and puts out power to the run device or removes ground (ignition). Check for power/ground at run device. 2. Control circuit overloaded by accessories (blown fuse in magnetic switch). 3. False ground in control circuit. 	<ol style="list-style-type: none"> 1. Reset magnetic switch and make sure it stays latched. Refer to installation instructions for 518PH magnetic switch (provided with unit). 2. Find blown fuse and replace (use 14 A fuse). Reroute the accessories. 3. Repair.
False shutdown.	<ol style="list-style-type: none"> 1. Swichgauge circuit has intermittent open or short. 2. Vibration causes the Magnetic Switch to trip. 	<ol style="list-style-type: none"> 1. Check all wiring and repair/replace as necessary. 2. Repair and relocate the switch as needed.
Swichgauge closes but does not trip the magnetic switch or kill the engine.	<ol style="list-style-type: none"> 1. Incomplete shutdown circuit. 2. Dirty Swichgauge contacts. 3. Ignition not providing power to primary terminal post. 4. Swichgauge case may not be grounded. 5. Incorrect magnetic switch for type of power. 	<ol style="list-style-type: none"> 1. Locate open circuit and repair. 2. Clean and check that contacts make. 3. Repair ignition. 4. Ground case. 5. Replace with correct magnetic switch.
Magnetic switch tripped but engine is still running.	<ol style="list-style-type: none"> 1. Open circuit between the magnetic switch and the shutdown device. 2. Lost ground to kill the engine. 	<ol style="list-style-type: none"> 1. Check wiring from magnetic switch to shutdown device, repair or replace. 2. Check all wiring and connections and repair.
Pointer will not operate properly. Inaccurate reading.	<ol style="list-style-type: none"> 1. Frozen pointer 2. Loose pointer spring (caused by hitting or dropping gage). 3. Plugged pressure orifice. 4. Over Pressure 	<ol style="list-style-type: none"> 1. Return for repair or replacement. 2. Return for repair or replacement. 3. Remove and clean. 4. Return for repair or replacement.
Pointer/contact burned-in two.	Without exception this condition is caused by incorrect wiring or short circuit.	Recheck wiring; replace Swichgauge or return for repair.

Warranty

A limited warranty on materials and workmanship is given with this FW Murphy product. A copy of the warranty may be viewed or printed by going to www.fwmurphy.com/support/warranty.htm

RJ Mann & Associates Inc.
Engine Controls & Panels/Compressor Parts

860 North 9th Avenue, Brighton, CO 80603
 Ph: (303) 659-5139 Fax: (303) 659-5309
www.rjmann.com