



STA16
SELECTRONIC® ALARM ANNUNCIATORS
DESIGN, INSTALLATION
AND OPERATING MANUAL



STA16



Certain danger to human safety and to equipment may occur if some equipment is stopped without pre-warning. It is recommended that monitored functions be limited to alarm-only or to alarm before shutdown.

WARNING

BEFORE BEGINNING INSTALLATION OF THIS MURPHY PRODUCT

- ✓ **Disconnect all electrical power to the machine.**
- ✓ **Make sure the machine cannot operate during installation.**
- ✓ **Follow all safety warnings of the machine manufacturer.**
- ✓ **Read and follow all**

Table of Contents

Section 1: Introduction	<i>page</i> 1
Section 2: Specifications	1
A. Power Requirements	1
B. Voltage Sensing Circuits	1
C. Output Ratings	1
D. Temperature Range	1
E. Dimensions	1
F. Enclosure	1
Section 3: Standard Features	1
A. General Operation	1
C. STA16	2
E. Optional Features	2
Section 4: Installation Operation	2
A. Electrical	2
B. Mechanical	2
C. Applications	2
D. Voltage Sensing Circuits	2
Figures:	
Figure 1a: STA16 Typical LED Display with Terminal Designation and Label Installation	3
Figure 3: STA16-N Circuit Diagram	4
Figure 8: STA16 Dimensions for Installation	4
Appendix A: Battery Charging Rates	5



CAUTION: Certain dangers to human safety and to equipment may occur if some equipment is stopped without pre-warning. It is recommended that monitored functions be limited to alarm-only or to alarm before shutdown.

Section 1: Introduction

- A.** This manual is directed to the design, installation, and operation of the Murphy model STA16 remote alarm annunciator. This remote annunciator monitors generator sets and indicates the cause of alarm when an operational fault occurs.
- B.** The Murphy family of remote alarm annunciators is designed to indicate the cause of an alarm using both visual and audio means. The audible alarm can be silenced by the operator, but the flashing warning light remains on to indicate the fault. These models are compatible with SWICHGAGE®s: the most versatile and practical engine sensor/switch available.
- C. Application**
The STA16 is a remote annunciator designed for emergency power systems. This model has sixteen LED alarm points which can be both visual and audible or visual only when specified. A high battery voltage and a low battery voltage sensor are included. The STA16 can be configured to meet NFPA-110 Level 1 requirements for remote alarm annunciators. This unit is typically used where a remote annunciator is needed at a 24 hour manned post to monitor the generator set.
STA16 series is available with N (negative) switch inputs only.

Section 2: Specifications

- A. Power Requirements**
- 1. Voltage:** STA16: 12 V or 24 V
 - 2. Current**
STA16
 - 12 V negative, standby 23 mA, max current (test) 60 mA
 - 24 V negative, standby 23 mA, max current (test) 70 mA
- B. Voltage Sensing Circuits** sense input voltage to ST family. Standard voltage set points are for lead acid batteries. Other battery types require different voltage settings.
- STA16: 12 VDC - High battery voltage sensing circuit; set at 14.5V. Low battery voltage sensing set at 10 V.
 - STA16: 24 VDC - High battery voltage sensing circuit; set at 29 V. Low battery voltage sensing set at 20 V.
- NOTE:** Other nominal voltages (8-40 VDC) can be provided upon request. Specify Battery Charger Malfunction low and high voltage sensing circuit set points if they are different from the settings listed under B. Voltage Sensing Circuits.
- C. Output Ratings**
STA16: 500 mA@ rated voltage for an external relay.
- D. Temperature Range:** -4°F to 158°F (-20°C to 70°C)
- E. Dimensions** (see Figures 7 and 8 page 9)
STA16
- a. Height 9-3/4 in. (248 mm)
 - b. Width 6-1/2in. (165 mm)
 - c. Depth 2-1/2 in. (64 mm)
- F. Enclosure**
STA16: Black ABS Plastic

Section 3: Standard Features

A. General Operation

A remote contact closure will turn on the alarm light and the common audible alarm. If the remote contact opens, the light and the audible alarm will turn off.

If the alarm silence switch is operated, the audible alarm will turn off, but the light will remain on as long as the contact is closed.

If another remote contact closes before all previous alarm contacts clear, the light will turn on, but the audible alarm will not sound.

The alarm silence switch circuit used in the STA16 is an automatic reset type that complies with the exception to paragraph 3-5.6.2 of NFPA-110-1996. The alarm silence circuit does not require manual reset after all previous faults clear to sound the audible alarm on another fault.

B. STA16

- 1.** 16 red LED alarm points; (unlabeled) A label sheet is included which contains all required and optional labels per NFPA 110. (See figure 1a, page 3 for LED and label information.)
- 2.** Mini-siren audible alarm.
- 3.** Output for external relay.
- 4.** Alarm silence push button.
- 5.** Test push button checks the alarm LEDs.
- 6.** Green power on LED.
- 7.** All 16 alarm points are both visual and audible.
- 8.** High battery voltage sensing circuit with output at terminal 10. As long as input voltage remains below set point, there will be no alarm output (output sinks 50 mA).
- 9.** Low Battery Voltage sensing circuit with output at terminal 9. As long as input voltage is above set point there will be no alarm output. (output sinks 50 mA).
- 10.** The low voltage bypass input at terminal 21 may be used to prevent low battery voltage alarm while engine is cranking.

C. Optional Features (These features must be ordered separately.)

STA16: All 16 lights can be changed in color and function. The color choices are green, amber, and red. The alarm points can be both visual and audible or visual only when specified.

Section 4: Installation Operation

- A. Electrical:** Circuit configuration for STA16-N is shown in Fig. 3.
- Remote Annunciator wire size:** Most STA16 series remote annunciators are installed in the cover of a pull box or similar enclosure and should be wired with the smallest stranded copper wire that complies with local codes. This will make it easier to stuff the excess wire into the pull box when the cover is installed and will put less strain on the ST terminal block and printed circuit board. Although the signal wires for the remote annunciators may be almost any size, the STA16 internal voltage sensing circuits require that the power wiring be sized so that full voltage is available at the input power terminals. The maximum voltage drop between the battery and the remote ST must be less than the difference between the low voltage set point and the battery float charging voltage or the alarm will sound prematurely. The maximum current requirements for the ST family is shown in Section 2: A.2. Section 2:B lists the standard voltage sensing set points. With maximum current, low voltage set point, the float charging voltage (see Appendix A) and the average resistance of copper wire you can calculate the minimum wire size or maximum distance of any wire size that you can run to the remote ST location. As an example, the STA16-N-24 draws a maximum current of 250

mA in the test mode and the low voltage setting of the low battery voltage sensing circuit is 20 volts. On a 24 volt lead acid battery system, the typical float charge is 26.04 volts. Therefore you cannot have more than 6.04 volt drop in the wiring without the alarm sounding. Maximum resistance would be maximum volt drop (6.04) divided by maximum current (250 mA) or 24.2 ohms on the STA16-N-24 with a 1/3 safety factor, the maximum resistance should be no more than 16.1 ohms. Using the average resistance of stranded copper wire per 1000 foot, you can then determine the distance that a given wire size can be run without causing a problem. Remember that two wires are required for the battery power so divide the result by 2 to get maximum length for each wire. How far can an STA16-N-24 be installed from the battery using 24 AWG wire? Wire resistance is 24 ohms per 1000 feet. The following chart can be used for wire sizes from 24 thru 14 AWG, on lead acid battery systems. The above formula can be applied to any type battery system. Because DC circuits can be affected by capacitance and other affects in long wire runs, we do not recommend runs longer than 1000 ft.

B. Mechanical: The dimensions and installation for the STA16 are shown on page 4.

C. Voltage Sensing Circuits: The Voltage sensing circuits are pre-set at the factory as shown in Section 2, B. All voltage sensing is done at the input terminals of the STA16 so it is very important that the input power wires are large enough to prevent unwanted voltage drops.

Set points in the STA16 cannot be adjusted in the field since their enclosures should not be opened by field personnel.

MODEL	Standard Copper Wire					
	24 AWG (.22 mm ²) 24 Ohm/1000	22 AWG (.5 mm ²) 14 Ohm/1000	20 AWG (.75 mm ²) 10 Ohm/1000	18 AWG (1.0 mm ²) 6 Ohm/1000	16 AWG (1.5 mm ²) 4 Ohm/1000	14 AWG (2.5 mm ²) 2.5 Ohm/1000
STA16-N 12V	334	573	800	1338	2000	3200
STA16-N 24V	670	1150	1610	2680	4025	6440

Figure 1a: STA16 Typical LED display and label sheet information

Select the needed labels and follow directions for their application. These are permanent, precut and pressure sensitive labels. Be sure the unit's faceplate is clean and free of oil.

1. Peel one label at the time and position on the unit's faceplate.
2. Before pressing down, be sure the label is correct.
3. Rub down firmly and leave untouched for several hours.

Label sheet supplied with STA16

- AFTERCOOLER TEMPERATURE
- AFTERCOOLER WATER LEVEL
- AIR FILTER
- AIR PRESSURE
- BEARING PRESSURE
- BEARING TEMPERATURE
- BILGE LEVEL
- CLUTCH AIR PRESSURE
- DAY TANK #1
- DAY TANK #2
- DAY TANK #3
- DAY TANK #4
- ENGINE OIL PRESSURE
- ENGINE OIL TEMPERATURE
- ENGINE ROOM TEMPERATURE
- ENGINE WATER LEVEL
- ENGINE WATER PRESSURE
- ENGINE WATER TEMPERATURE
- EXHAUST TEMPERATURE
- FIRE ALARM
- FUEL FILTER
- FUEL LEVEL
- FUEL PRESSURE
- FUEL RESTRICTION
- FUEL SEPARATOR WATER LEVEL
- GEAR OIL PRESSURE
- GEAR OIL TEMPERATURE
- GENERATOR OIL PRESSURE
- GENERATOR WATER TEMP.
- GENERATOR #1 OIL PRESSURE
- GENERATOR #1 WATER TEMP.
- GENERATOR #1 WATER LEVEL
- GENERATOR #2 OIL PRESS.
- GENERATOR #2 WATER TEMP.
- GENERATOR #2 WATER LEVEL
- HYDRAULIC LEVEL
- LOW VOLTAGE
- MANIFOLD BOOST
- MANIFOLD TEMPERATURE
- OVERSPEED
- PORT
- PORT GENERATOR ENGINE
- PORT MAIN ENGINE
- PORT OIL PRESSURE
- PORT WATER TEMPERATURE
- PORT OIL TEMPERATURE
- PORT WATER LEVEL
- PORT WATER PRESSURE
- RAW WATER PRESSURE
- STARBOARD
- STARBOARD GENER. ENGINE
- STARBOARD MAIN ENGINE
- STARBOARD OIL PRESSURE
- STARBOARD WATER TEMP.
- BILGE LEVEL
- STARBOARD OIL TEMPERATURE
- STARBOARD WATER LEVEL
- STARBOARD WATER PRESSURE
- TRANSMISSION OIL FILTER
- TRANSMISSION PRESSURE
- TRANSMISSION TEMPERATURE
- OIL PRESSURE/LEVEL
- WATER PRESSURE/LEVEL

Label sheet supplied with STA16

- AIR DAMPER CLOSED
- ALARM SILENCE
- BATTERY CHARGER MALFUNCTION
- C/B CLOSED
- C/B OPEN
- C/B TRIPPED
- COMMON FAILURE
- CONTROL SWITCH NOT IN AUTO
- EPS SUPPLYING LOAD
- FALLING OIL TEMP.
- GENERATOR NOT IN AUTO
- GENERATOR IN AUTO
- GENERATOR OPERATING
- GENERATOR SUPPLYING LOAD
- HIGH BATTERY VOLTAGE
- HIGH ENGINE TEMPERATURE
- HIGH ENGINE TEMP. PREALARM
- HIGH OIL TEMPERATURE
- HIGH OIL TEMP. PREALARM
- HIGH WATER TEMPERATURE
- HIGH WATER TEMP. PREALARM
- LOW BATTERY VOLTAGE
- LOW FUEL LEVEL
- LOW FUEL DAY TANK
- LOW FUEL MAIN TANK
- LOW FUEL PRESSURE
- LOW OIL LEVEL
- LOW OIL PRESSURE
- LOW OIL PRESSURE PREALARM
- LOW OIL TEMPERATURE
- LOW STARTING AIR PRESSURE
- LOW STARTING HYDRAULIC PRESS.
- LOW WATER LEVEL
- LOW WATER PRESSURE.
- LOW WATER TEMPERATURE
- OVERCRANK
- OVERCURRENT
- OVERSPEED
- OVER/UNDER FREQUENCY
- OVERVOLTAGE
- POWER ON
- RISING WATER TEMPERATURE
- SELECTOR NOT IN AUTO
- TEST
- VIBRATION
- LOW WATER LEVEL SHUTDOWN
- HIGH COOLANT TEMPERATURE
- HIGH COOLANT TEMP. PREALARM
- LOW COOLANT TEMPERATURE
- LOW COOLANT TEMP. PREALARM
- BATTERY CHARGER AC FAILURE

STA16 Typical LED display

(terminal numbers are in parenthesis)

NOTE: STA16 faceplate is blank—labels must be applied.

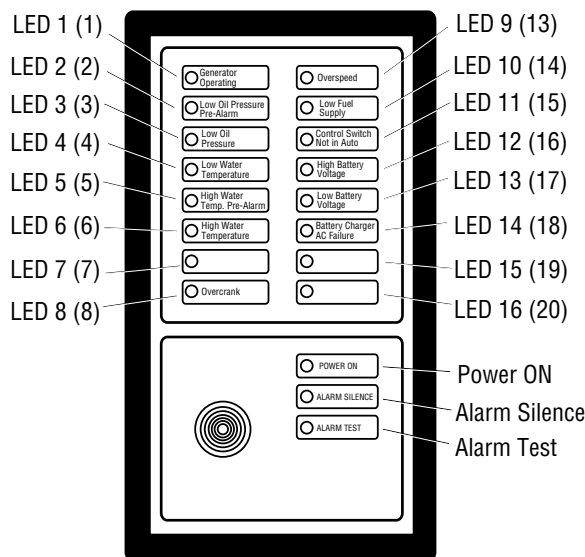
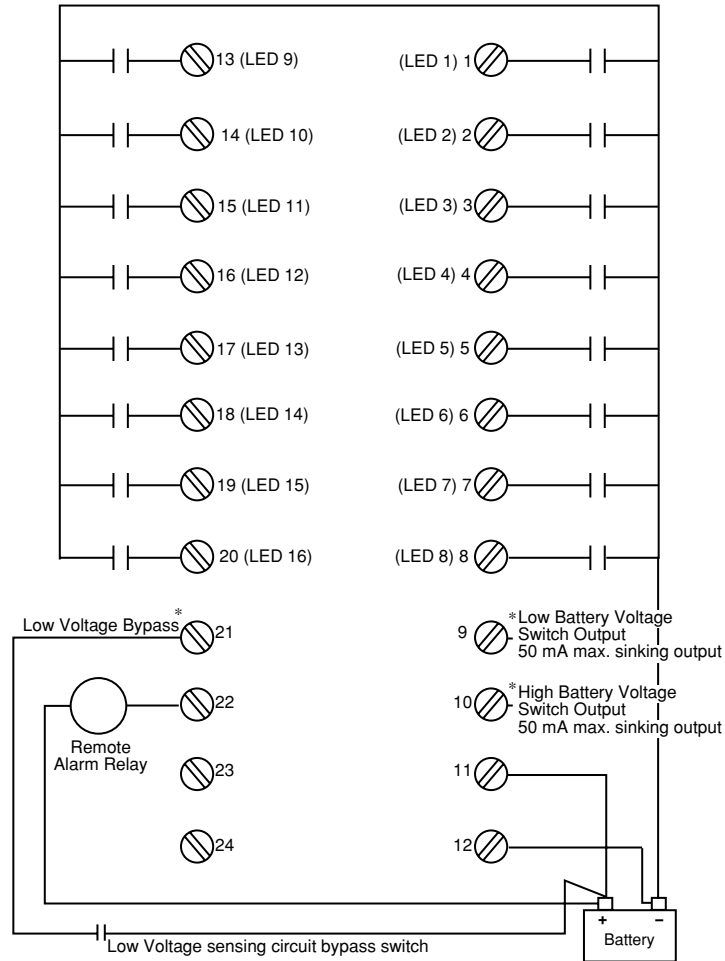
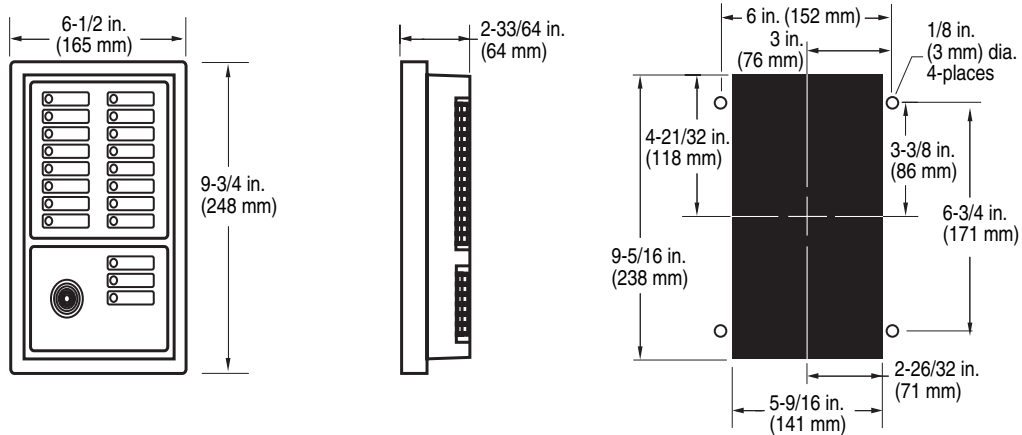

Figure 3: STA16-N



* **NOTE:** Internal voltage sensing circuit switch outputs. These can be wired to any of the alarm inputs for high or low battery voltage alarm. Low voltage bypass prevents the low voltage switch from operating when terminal 21 is connected to battery positive.

Figure 8: STA16 Dimensions and Installation



Appendix A

Battery Charging Rates

Model STA16 includes a voltage sensing circuit to detect battery charger malfunction. This is done by sensing that the battery voltage is either below or above normal charging voltage of a properly operating battery charger. Standard setting is for lead acid type batteries.

Most battery chargers have two operating modes; float and equalize. The sensing circuits of the STA16 is set at 96% of the equalize voltage so that normal operation of the charger is covered.

Typical battery charging rates.

Lead Acid Batteries

Float Charge	2.17 Volts per cell
Equalize Charge	2.33 Volts per cell

Nickel Cadmium Batteries

Float Charge	1.4 Volts per cell
Equalize Charge	1.5 Volts per cell

Nominal battery sizes.

Lead Acid Batteries

12 Volt	6 cells
24 volt	12 cells

Nickel Cadmium Batteries

12 Volt	10 cells
24 Volts	20 cells

Therefore the charging voltage will be:

Lead Acid Batteries

12 volt float	13.02 Volts
12 Volts equalize	13.98 Volts
24 Volt float	26.04 Volts
24 Volts equalize	27.96 Volts

Nickel Cadmium Batteries

12 Volt float	14 Volts
12 Volt equalize	15 Volts
24 Volt float	28 Volts
24 Volt equalize	30 Volts

The standard settings for the low and high battery voltage circuit in the STA16 are shown below.

Lead Acid Batteries

12 Volt low	10.00 Volts
12 Volt high	14.50 Volts
24 Volt low	20.00 Volts
24 Volt high	29.00 Volts

Nickel Cadmium Batteries

12 Volt low	10.78 Volts
12 Volt high	15.60 Volts
24 Volt low	21.56 Volts
24 Volt high	31.20 Volts

Although the above figures are our standards, we can set the sensing circuits at any value that is required to match the sensor to a battery charger or alternator. The sensors can be factory set to any value between 8 and 40 volts DC.

Warranty

A limited warranty on materials and workmanship is given with this FW Murphy product.
A copy of the warranty may be viewed or printed by going to www.fwmurphy.com/support/warranty.htm

RJ Mann & Associates Inc.

Engine Controls & Panels/Compressor Parts

860 North 9th Avenue, Brighton, CO 80603
Ph: (303) 659-5139 Fax: (303) 659-5309
www.rjmann.com

